

SWEET3 7KW WIFI

Gruppo estetico / Aesthetic group / Ästhetische Gruppe / Groupe esthétique / Grupo estético

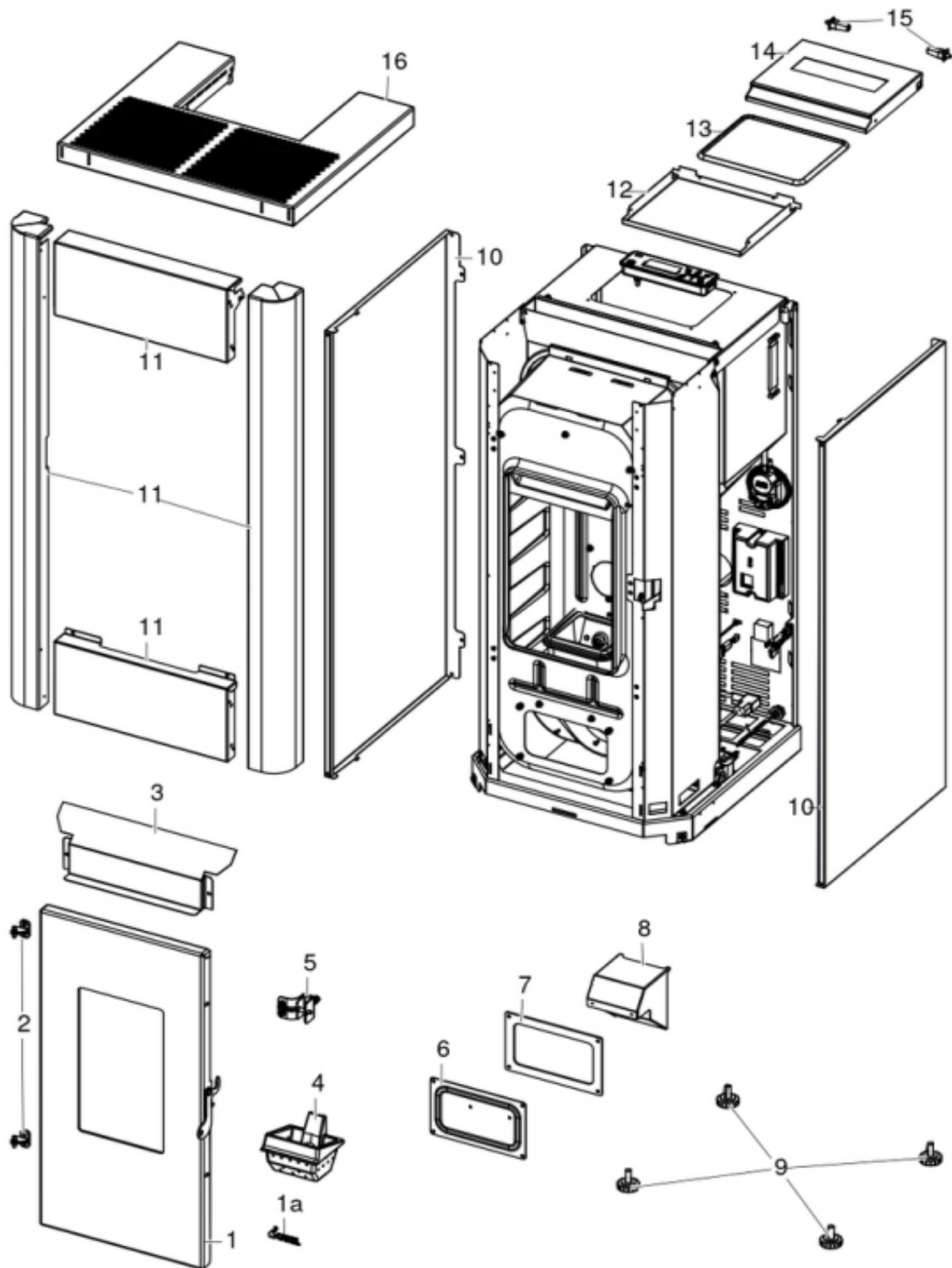

N°	Codice/Code	Descrizioni / Description / Beschreibung / Description / Descripcion
1	4D245GP21006	Gruppo Porta / Door / Tür / Porte / Puerta
1a	4D12013039	Logo Cadel / Cadel logo / Cadel Logo / Cadel logo / Cadel logo
2	41201504460	Cerniera porta (2 pz.) / Door hinge (2 pc.) / Tür Scharnier (2 Stk.) / Charnière porte (2 pc.) / Bisagra puerta (2)
3	4D241201203	Carter paracalore / Heat shield / Hitzeschild / Bouclier thermique / Escudo térmico
4	4D130158010	Braciere / Grate / Brennschale / Brascero / Brascero
5	4D241201090	Aggancio porta / holder hook / Türhalter / Crochet porte / Gancho de puerta
6	4D241201070	Tappo ispezione / Inspection cap / Inspektionskappe / Bouchon d'inspection / Tapa de inspección
7	4D180201020	Guarnizione / Gasket / Dichtung / Joint / Junta
8	4D241201273	Deviatore fumi caldaia / Boiler smoke diverter / Kessel Rauchableitung / Inverseur de fumée de chaudière / Desviador de humos de caldera
9	4D120201020	Piedino (4 pz) / Feet (4 Pcs) / Füße (4 Stck) / Vérins (4 Pcs) / Pies (4 pz)
10	4D24020102363	Fianco dx-sx / RH-LH side / R.-L. Seite / Côté droite et gauche / Lateral DCHO - IZDO
11	6920024	Rivestimento Antracite / Cladding Anthracite / Verkleidung Anthrazit / Habillage Anthracite / Revestimiento Antracite
11	6920025	Rivestimento Bianco / Cladding White / Verkleidung Weiss / Habillage Blanc / Revestimiento Blanco
11	6920026	Rivestimento Rosso / Cladding Red / Verkleidung Rot / Habillage Rouge / Revestimiento Rojo
12	4D241201213	Controcoperchio serbatoio / Hopper counter top / Pellet Tank-Gegendeckel / Contre-couvercle de réservoir / Contra-tapa del tanque
13	4D18013016	Guarnizione 155X190 mm / Gasket 155X190 mm / Dichtung 155x190 mm / Joint 155X190 mm / Junta 155X190 mm
14	4D24020108363	Coperchio plt / Cover plt / Deckel plt / Couvercle plt / Tapa plt
15	4D14013054C	Cerniera a innesto (2 pz) / Hinge (2 pc) / Scharnier (2 Stck) / Charnière (2 pcs) / Bisagra (2 pzs)
16	4D24020101361	Top / Top / Dessus / Top / Top

SWEET3 7KW WIFI

Porta fuoco / Fire door / Feuertür / Porte foyer / Puerta hogar

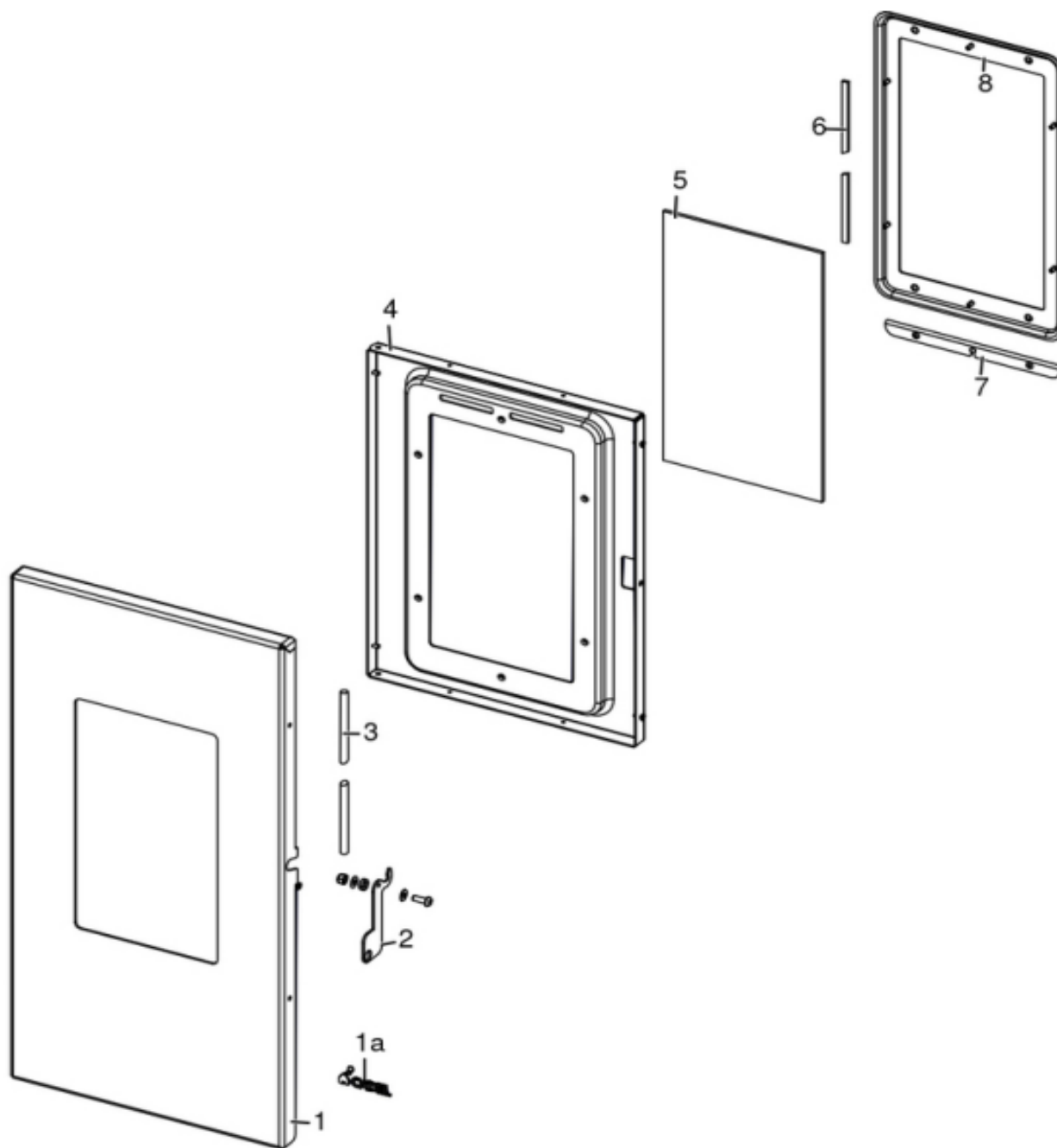

N°	Codice/Code	Descrizioni / Description / Beschreibung / Description / Descripción
1	4D24020103361	Facciata porta piccola / Small door front / Kleine Türfront / Petite façade de porte / Frente de puerta pequeña
1a	4D12013039	Logo Cadel / Cadel logo / Cadel Logo / Cadel logo / Cadel logo
2	4D24016014161	Maniglia / Handle / Griff / Poignée / Tirador
3	4D180201110	Treccia tricotex nera Ø8 / Black tricotex braid Ø8 / Schwarzes Trikotexgeflecht Ø8 / Tresse tricotex noire Ø8 / Trenza tricotex negra Ø8
4	4D241201140	Porta stampata (telaio A) / Molded door (frame A) / Geformte Tür (Rahmen A) / Porte moulée (cadre A) / Puerta moldeada (marco A)
5	4D170201010	Vetro ceramico 310X182 / Ceramic glass 310X182 / Glaskeramikscheibe 310X182 / Vitre en céramique 310X182 / Cristal cerámico 310X182
6	4D180201010	Nastro adesivo nero / Black adhesive tape / Schwarzes Klebeband / Ruban adhésif noir / Cinta adhesiva negra
7	4D241201310	Paracenera porta / Ashtray door / Aschenbecher Tür / Porte de cendrier / Puerta del cenicero
8	4D241201150	Porta stampata (telaio B) / Molded door (frame B) / Geformte Tür (Rahmen B) / Porte moulée (cadre B) / Puerta moldeada (marco B)

SWEET3 7KW WIFI

Gruppo caricamento pellet / Pellet feed group / Pellet Fördergruppe / Groupe chargement du pellet / Grupo de carga pellet

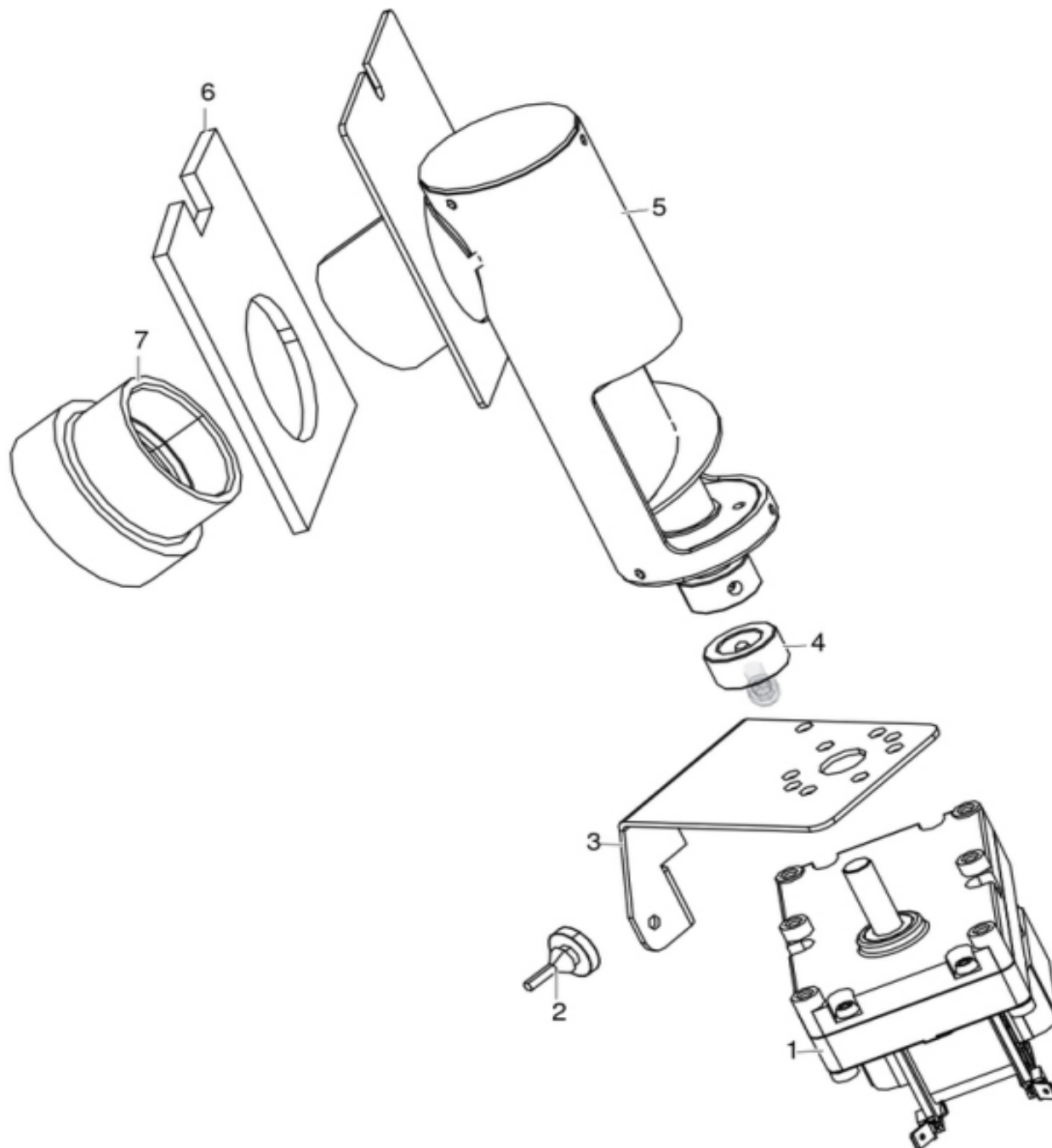

N°	Codice/Code	Descrizioni / Description / Beschreibung / Description / Descripcion
1	4D145181020	Motoriduttore 2 rpm / Reduction motor 2 rpm / Getriebemotor 2 rpm / Motorréducteur 2 rpm / Motorreductor 2 rpm
2	4D120172010K	Kit 4 paracolpi / Kit 4 Bumpers / Kit 4 Schlagschutzgummi / Kit 4 pièces antichoc / Kit 4 anti-golpes
3	4D241198043	Staffa / Bracket / Haltebügel / Etrier / Abrazadera
4	4120398	Connettore motoriduttore-coclea / Reduction motor-feed screw connector / Verbindung Getriebemotor-Schnecke / Connecteur motorréducteur-vis sans fin / Conector motorreductor-cóclea
5	4D140219014	Coclea corta alluminio 7 Kw / Short feed screw aluminum 7 Kw / Kurz Förderschnecke Aluminium 7 Kw / Vis sans fin courte aluminium 7 Kw / Cóclea corta aluminio 7 Kw
6	41802000300	Guarnizione con ceramica gruppo alimentazione / Gasket with ceramic - power supply group / Dichtung mit Keramik - Stromversorgungsgruppe / Joint avec céramique - groupe d'alimentation / Junta con cerámica - grupo de alimentación
7	41801702600	Disaccoppiatore coclea / Feed screw gasket / Dichtung Pelletrutsche / Joint vis sans fin / Desacoplador cóclea

SWEET3 7KW WIFI

Gruppo elettrico ed elettronico / Electrical and electronic group / Elektrische und elektronische Gruppe / Groupe électrique et électronique / Grupo eléctrico y electrónico

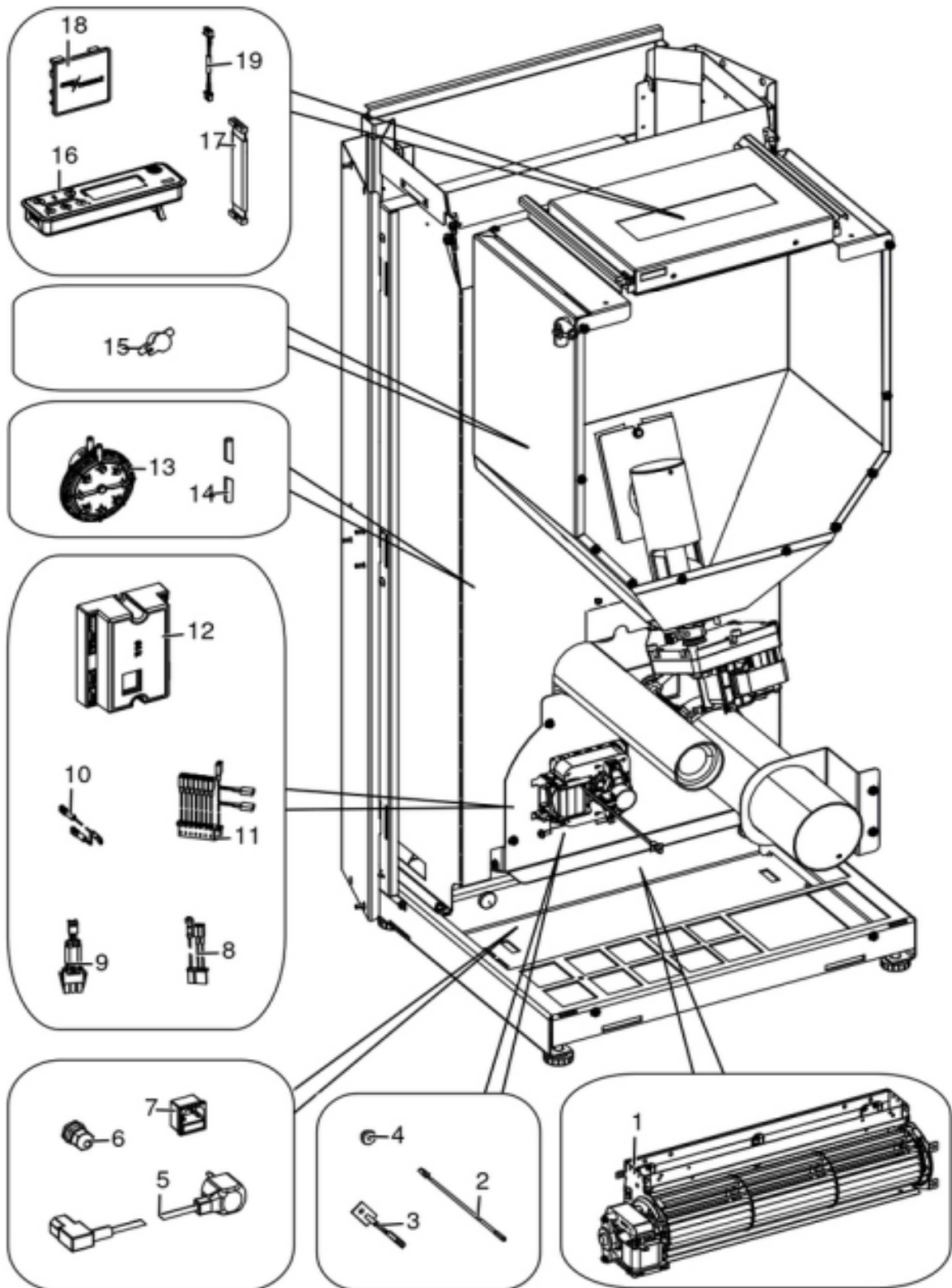

N°	Codice/Code	Descrizioni / Description / Beschreibung / Description / Descripción
1	4D145201010	Ventilatore / Fan / Luft Gebläse / Ventilateur air / Ventilador aire
2	4D145150100	Sonda ambiente / Room temperature sensor / Raumtemperaturfühler / Sonde température ambiance / Sonda ambiente
3	4D145194010	Sonda fumi / Smoke sensor / Rauchgasfühler / Sonde fumées / Sonda humos
4	4D180201070	Guarnizione sonda fumi / Smoke probe gasket / Rauchsonden-Dichtung / Joint de sonde de fumée / Junta de sonda de humo
5	4D14513041	Cavo alimentazione / Power source cable / Zündungskabel / Câble alimentation / Cable alimentación
6	4D14513018	Pressacavo + cont. Dado / Cable holder / Kabelklemme / Presse-cable / Presionacable
7	4D14513084	Cavo con spina Shucko / Cable with Shucko plug / Kabel mit Schucko Steckdose / Cable avec fiche Shucko / Cable con enchufe Schucko
8	4D145183040	Cablaggio 3 Pin completo / Complete wiring kit 3 Pin / Komplette Verkabelung 3 Pin / Câblage complet 3 Pin / Cableado completo 3 Pin
9	4D145194020	Cavo Encoder / Encoder cable / Encoder Kabel / Câble encoder / Cable encoder
10	4D145201040	Cavo massa / Grounding wiring / Erdungskabel / Câbla mise à terre / Cableado a tierra
10	4D14513060	Cavo massa 130 mm / Mass cable 130 mm / Masse Kabel 130 mm / Cable masse 130 mm / Cable masa 130 mm
11	4D145201170	Cablaggio / Wiring / Verkabelung / Câblage / Cableado
12	4D1452002300A	Scheda madre / Motherboard / Hauptplatine / Carte mère / Tarjeta madre
13	4D145181110	Pressostato / Pressure switch / Druckwächter / Pressostat / Presostato
14	4120631A	Tubicino siliconico - 5m / Silicon tube - 5m / Silikonrohr - 5m / Petit tuyau en silicone - 5m / Tubo silicónico - 5m
15	4D14513006	Termostato 60°C / Thermostat 60°C / Thermostat 60°C / Thermostat 60°C / Termostato 60°C
16	4D1451303300	Pannello comandi grafico / Graphic control panel / Graphische Bedienblende / Tableau de commande / Panel de mandos gráfico
17	4D145158020	Cavo flat scheda-pannello / Flat cable motherboard-control panel / Flat Kabel Hauptplatine-Bedienblende / Câble flat carte mère-panneau commande / Cable flat tarjeta madre-panel de mandos
18	4D145201030	Modulo Wi-fi / Wi-fi module / Wi-Fi-Modul / Module Wi-fi / Módulo wifi
19	4D1452002500	Cavo flat 7 vie / Flat cable / Flat-Kabel / Cable flat / Cables flat

SWEET3 7KW WIFI

Gruppo aria comburente / Combustion air group / Verbrennungsluft Gruppe / Groupe air comburant / Grupo aire comburente

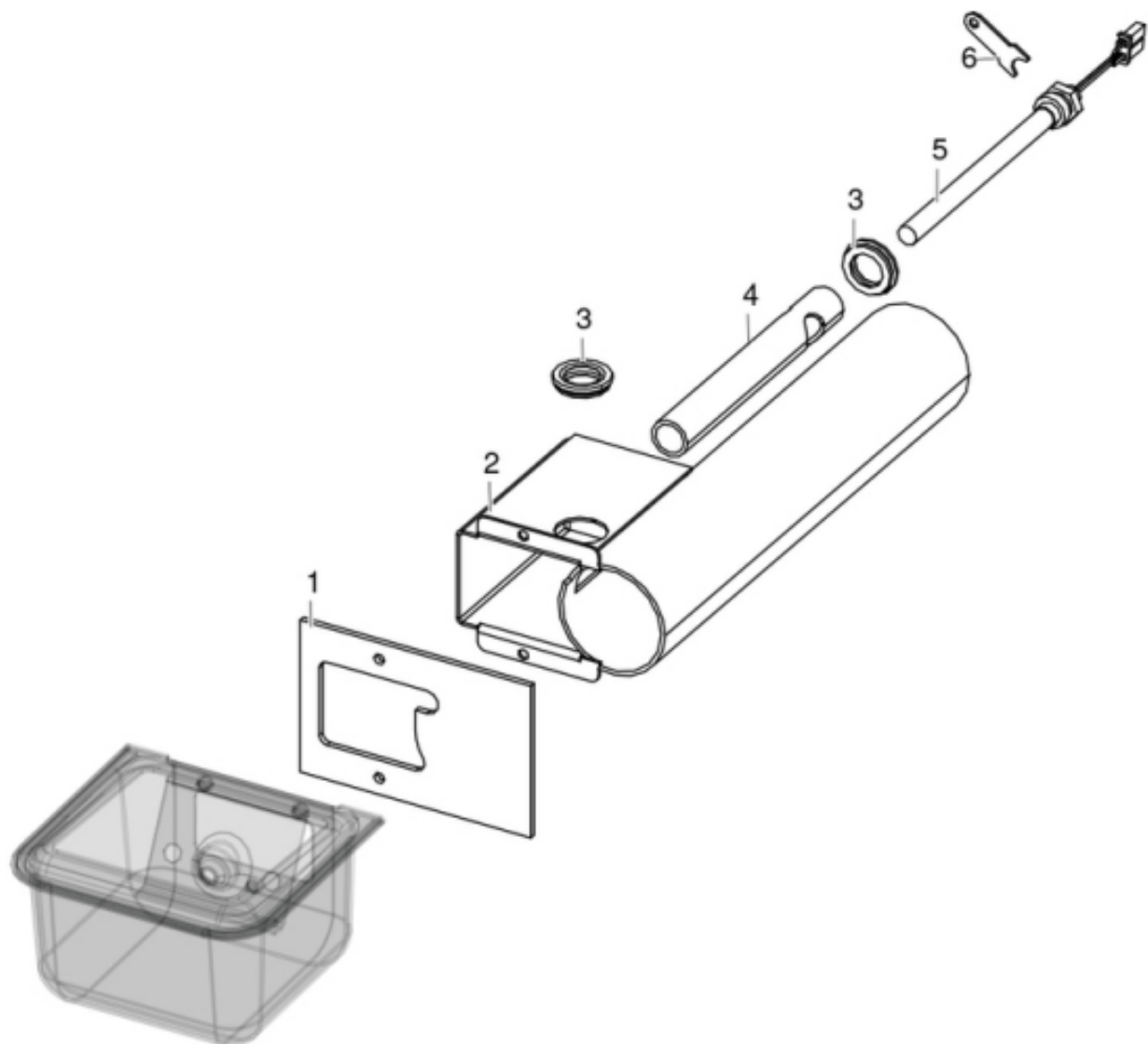

N°	Codice/Code	Descrizioni / Description / Beschreibung / Description / Descripción
1	4D180201020	Guarnizione / Gasket / Dichtung / Joint / Junta
2	4D24020135463	Assieme codolo aria comburente / Combustion air tang assembly / Verbrennungsluft Zapfenbaugruppe / Ensemble de tenons d'air de combustion / Conjunto de espiga de aire de combustión
3	4D180201030	Guarnizione tubo candelella Ø28 / Ø28 sparkplug tube gasket / Ø28 Glühkerzen Rohrdichtung / Joint de tube de bougie de préchauffage Ø28 / Junta tubo bujía incandescente Ø28
4	4D12013002	Portacandelella / Sparkplug holder / Zündkerzenhalter / Support de bougie / Apoyo bujía
5	4D145181040	Candelella / Sparkplug / Zündkerze / Bougie / Bujía
6	4D241201320	Ferma candelella / Spark Plug lock / Zündkerze Feststeller / Arrêter Bougie / Detener Bujía

SWEET3 7KW WIFI

Gruppo fumi / Smoke group / Rauchgruppe / Groupe fumées / Grupo de humos

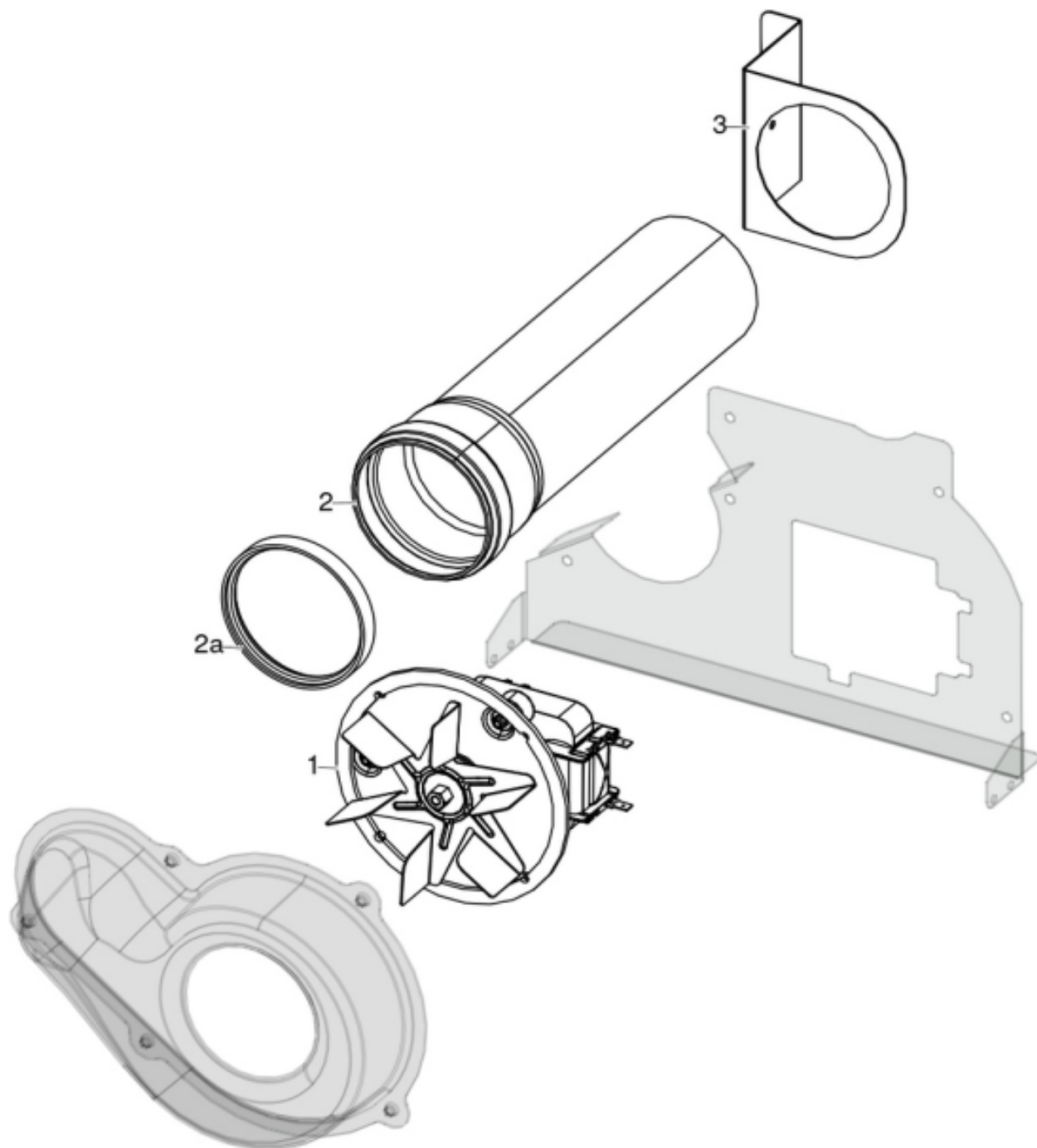

N°	Codice/Code	Descrizioni / Description / Beschreibung / Description / Descripcion
1	4D145210050	Ventilatore fumi / Smoke exhaust fan / Rauchgasgebläse / Ventilateur aspiration fumées / Ventilador humos
1	41452009200	Encoder EMC FIME / Encoder EMC FIME / Encoder EMC FIME / Encoder EMC FIME / Encoder EMC FIME
1	4D145209170	Encoder per ventilatore fumi marchi TRIAL / Encoder for TRIAL smoke fan / Encoder für TRIAL Rauchgasgebläse / Encoder pour ventilateur des fumées marques TRIAL / Encoder para ventilador humos marcas TRIAL
1	4D180221020	Guarnizione / Gasket / Dichtung / Joint / Junta
2	41601604560	Tubo Ø 8 L.29 nero con guarnizione / Black tube Ø 8 L.29 with gasket / Schwarzes Rohr Ø 8 L.29 mit Dichtung / Tube noir Ø 8 L.29 avec joint / Tubo negro Ø 8 L.29 con junta
2a	40120969	Guarnizione siliconica Ø 8 / Silicon gasket Ø 8 / Silikonsichtung Ø 8 / Join en silicon Ø 8 / Junta de silicona Ø 8
3	4D241209143	Supporto tubo scarico fumi / Smoke exhaust pipe support / Abgasrohr Auslasshalterung / Support de sortie de conduit de fumée / Soporte para tubo de escape de humos