

FRAME3 9KW

Gruppo estetico / Aesthetic group / Ästhetische Gruppe / Groupe esthétique / Grupo estético

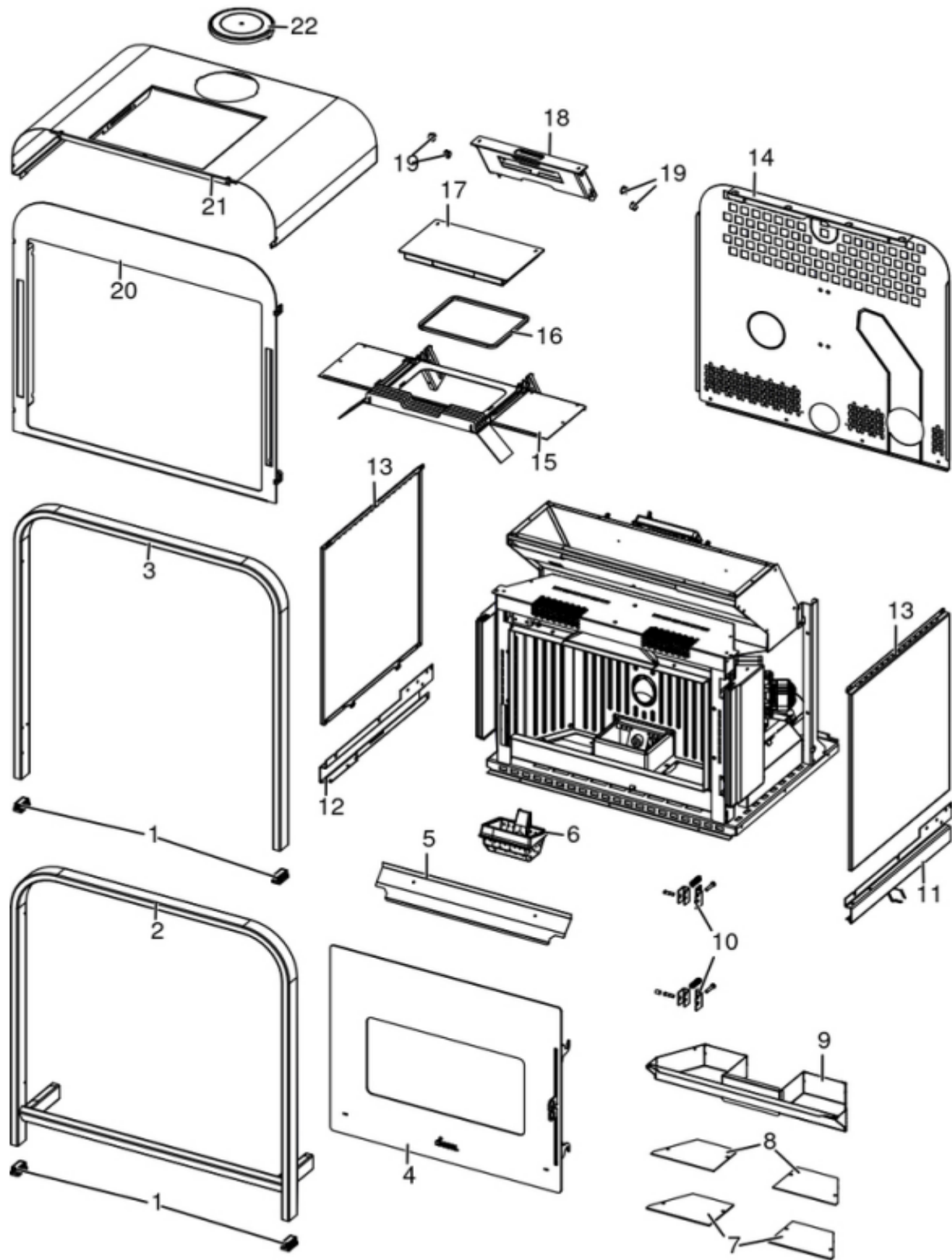

N°	Codice/Code	Descrizioni / Description / Beschreibung / Description / Descripcion
1	4D180184050	Tappo rettangolare nero (4pz) / Rectangular black cover (4Pcs) / Rechteckige schwarze Deckel (4Stk) / Bouchon noir rectangulaire (4Pcs) / Tapon rectangular negro (4pz)
2	4D16018308016	Tubo anteriore Light Bronze / Front pipe Light Bronze / Rohr vorne Light Bronze / Conduit antérieur Light Bronze / Tubo anterior Light Bronze
2	4D16018308041	Tubo anteriore Antracite / Front pipe Anthracite / Rohr vorne Anthrazit / Conduit antérieur Anthracite / Tubo anterior Antracita
2	4D16018308063	Tubo anteriore Nero / Front pipe Black / Rohr vorne Schwarz / Conduit antérieur Noir / Tubo anterior Negro
3	4D16018306016	Tubo posteriore Light Bronze / Back pipe Light Bronze / Rohr hinten Light Bronze / Conduit postérieure Light Bronze / Tubo posterior Light Bronze
3	4D16018306041	Tubo posteriore Antracite / Back pipe Anthracite / Rohr hinten Anthrazit / Conduit postérieure Anthracite / Tubo posterior Antracita
3	4D16018306063	Tubo posteriore Nero / Back pipe Black / Rohr hinten Schwarz / Conduit postérieure Noir / Tubo posterior Negro
4	4D245GP18016	Porta completa / Complete door / Komplette Tür / Porte complete / Puerta completa
4	4D241203503	Kit staffe / Brackets kit / Haltebügelsatz / Kit étriers / Kit soportes
5	4D242183063	Staffa / Bracket / Haltebügel / Etrier / Abrazadera
6	4D13016602061	Braciere / Grate / Brennschale / Brascero / Brascero
7	4D180184080	Guarnizione tappo fumi / Smoke plug gasket / Rauchgasklappe- Dichtung / Joint clapet fumées / Junta tapón humos
8	4D241183531	Tappo fumi DX / Smoke plug / Rauchgasklappe / Clapet fumées / Tapón humos
9	4D24018342461	Cassetto cenere / Ash drawer / Aschenkasten / Tiroir à cendres / Cajón ceniza
10	4D24015841361	Kit decompressione camera di combustione / Pressure relief kit / Bausatz Überdruckablauf Brennkammer / Kit decompression chambre de combustion / Kit decompression cámara de combustión
11	4D24018322316	Laterale SX Light Bronze / LH Light Bronze side / Linker Seitenteil Light Bronze / Côté gauche Light Bronze / Lateral IZDO Light Bronze
11	4D24018322341	Laterale SX Antracite / LH Anthracite side / Linker Seitenteil Anthrazit / Côté gauche Anthracite / Lateral IZDO Antracita
11	4D24018322363	Laterale SX Nero / LH Black side / Linker Seitenteil Schwarz / Côté gauche Noir / Lateral IZDO Negro
12	4D24018323316	Laterale DX Light Bronze / RH Light Bronze side / Rechter Seitenteil Light Bronze / Côté droite Light Bronze / Lateral DCHO Light Bronze
12	4D24018323341	Laterale DX Antracite / RH Anthracite side / Rechter Seitenteil Anthrazit / Côté droite Anthracite / Lateral DCHO Antracita
12	4D24018323363	Laterale DX Nero / RH Black side / Rechter Seitenteil Schwarz / Côté droite Noir / Lateral DCHO Negro
13	4D24018369363	Fianco DX-SX / RH-LH side / R.-L. Seite / Côté droite et gauche / Lateral DCHO - IZDO
13	4D241203503	Kit staffe / Brackets kit / Haltebügelsatz / Kit étriers / Kit soportes
14	4D241183273	Schiena / Back / Rückwand / Fond / Parte trasera
15	4D24018383463	Coperchio serbatoio pellet + griglia / Pellet hopper cover + grill / Deckel Pelletbehälter + Gitter / Couvercle réservoir pellet + grille / Tapadera depósito pellet + rejilla
16	4D18013016	Guarnizione 155X190 mm / Gasket 155X190 mm / Dichtung 155x190 mm / Joint 155X190 mm / Junta 155X190 mm
17	4D24018331463	Coperchio / Cover / Deckel / Couvercle / Tapa
18	4D24018333463	Porta display / Display holder / Display Träger / Porte-display / Porta Display
19	4D12013037	Tappo Ø 16 / Outlet Ø 16 / Deckel Ø 16 / Trappe Ø 16 / Tapón Ø 16
20	4D24018390461	Facciata / Face / Vorne / Facade / Frontal
21	4D24018368363	Coperchio / Cover / Deckel / Couvercle / Tapa
22	4D24018321016	Collare fumi Bronze / Bronze smoke collar / Rauchskragen Bronze / Col des fumées Bronze / Cuello de humos Bronze
22	4D24018321041	Collare fumi Antracite / Anthracite smoke collar / Rauchskragen Anthrazit / Col des fumées Anthracite / Cuello de humos Antracita
22	4D24018321063	Collare fumi Nero / Black smoke collar / Rauchskragen Schwarz / Col des fumées Noir / Cuello de humos negro

FRAME3 9KW

Porta fuoco / Fire door / Feuertür / Porte foyer / Puerta hogar

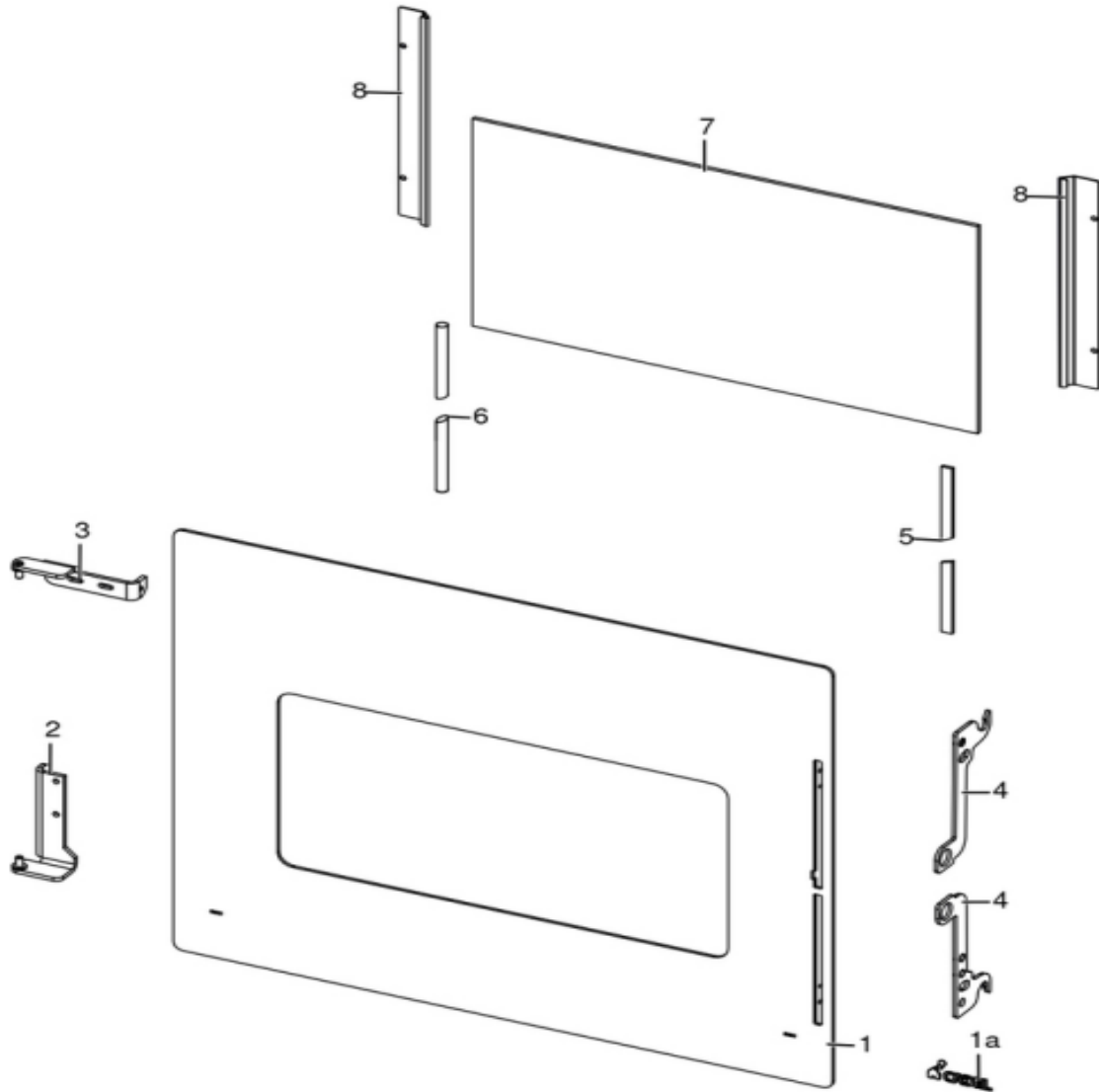

N°	Codice/Code	Descrizioni / Description / Beschreibung / Description / Descripcion
1	4D24018324461	Porta / Door / Tür / Porte / Puerta
1a	4D12013039	Logo Cadel / Cadel logo / Cadel Logo / Cadel logo / Cadel logo
2	4D24018387361	Cerniera inferiore / Lower hinge / Unteres Scharnier / Charnière inférieure / Bisagra inferior
3	4D24018386361	Cerniera superiore / Upper hinge / Oberes Scharnier / Charnière supérieure / Bisagra superior
4	4D24018391161	Gancio chiusura porta / Door closing hook / Haken Türschlissung / Crochet fermeture porte / Gancho cierre porta
5	4D18013008A	Guarnizione 10x3 (5m) / Gasket 10x3 (5m) / Dichtung 10x3 (5m) / Joint 10x3 (5m) / Junta 10x3 (5m)
5	4D18013008C	Guarnizione 10x3 (100m) / Gasket 10x3 (100m) / Dichtung 10x3 (100m) / Joint 10x3 (100m) / Junta 10x3 (100m)
6	4D180171010A	Treccia / Plait / Geflecht / Tresse / Trenza
7	4D170209010	Vetro ceramico sfilettato 468X251X5 / Filleted ceramic glass 468X251X5 / Filetiertes Keramikglas 468X251X5 / Vitre céramique fileté 468X251X5 / Vidrio cerámico fileteado 468X251X5
8	4D242183053	Fermavetro laterali / Lateral fastening brackets / Seitliche Scheibebefestigungen / Pattes de fixation laterales / Fermacristal lateral

FRAME3 9KW

Gruppo aria comburente / Combustion air group / Verbrennungsluft Gruppe / Groupe air comburant / Grupo aire comburente

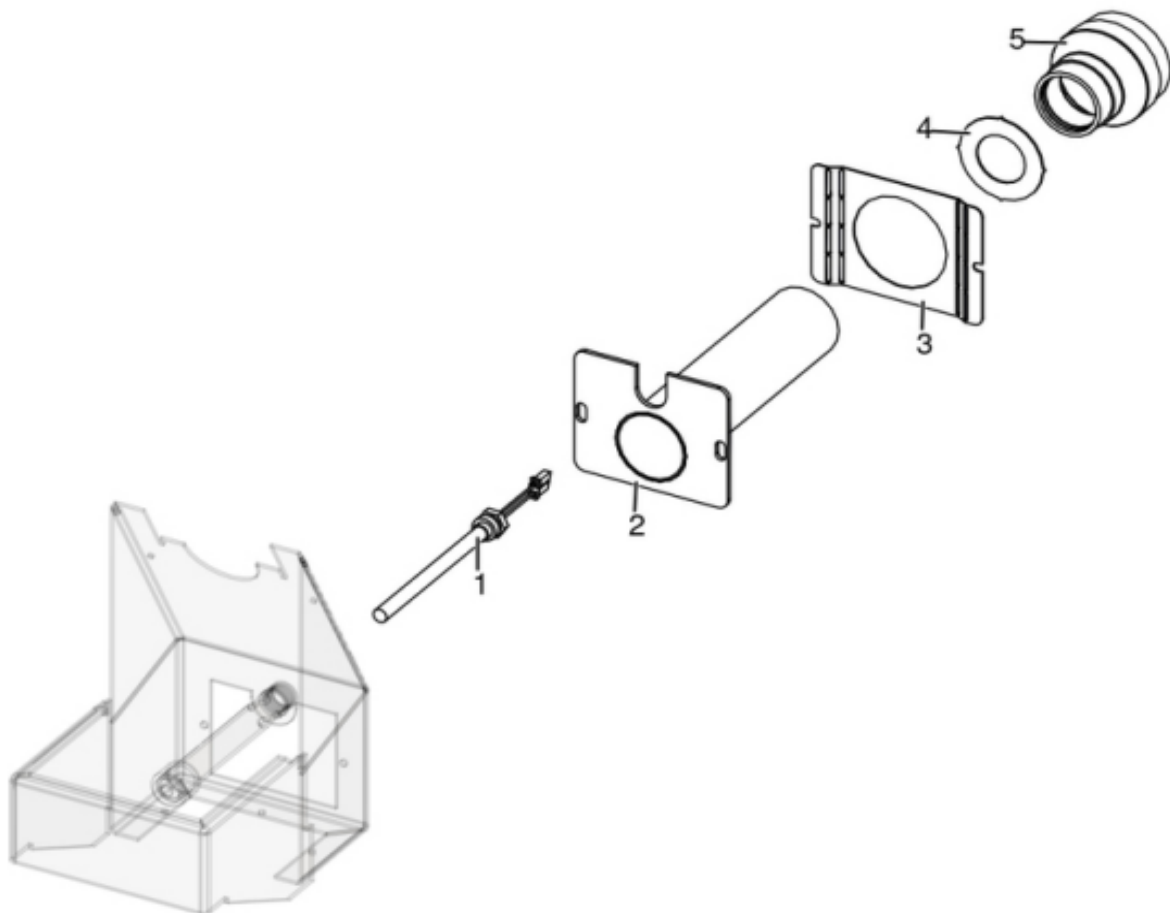

N°	Codice/Code	Descrizioni / Description / Beschreibung / Description / Descripcion
1	4D145181040	Candeletta / Sparkplug / Zündkerze / Bougie / Bujía
2	4D160183030	Insieme ingresso tubo aria / Air inlet pipe group / Lufteintritt- Rohrgruppe / Groupe conduit entrée d'air / Conjunto de entrada de tubo de aire
3	4D241183311	Staffa bloccaggio ingresso aria / Air inlet bracket / Lufteintritt Bügel / Étrier de blocage air / Abrazadera de aire
4	4D242183071	Strozzatore D. 35/59 mm / Adaptor D. 35/59 mm / Anpassungsteil D. 35/59 mm / Réducteur D. 35/59 mm / Reductor D. 35/59 mm
5	4D180150030	Raccordo / Connector / Anschlußrohr / Raccord / Racor

FRAME3 9KW

Gruppo caricamento pellet / Pellet feed group / Pellet Fördergruppe / Groupe chargement du pellet / Grupo de carga pellet

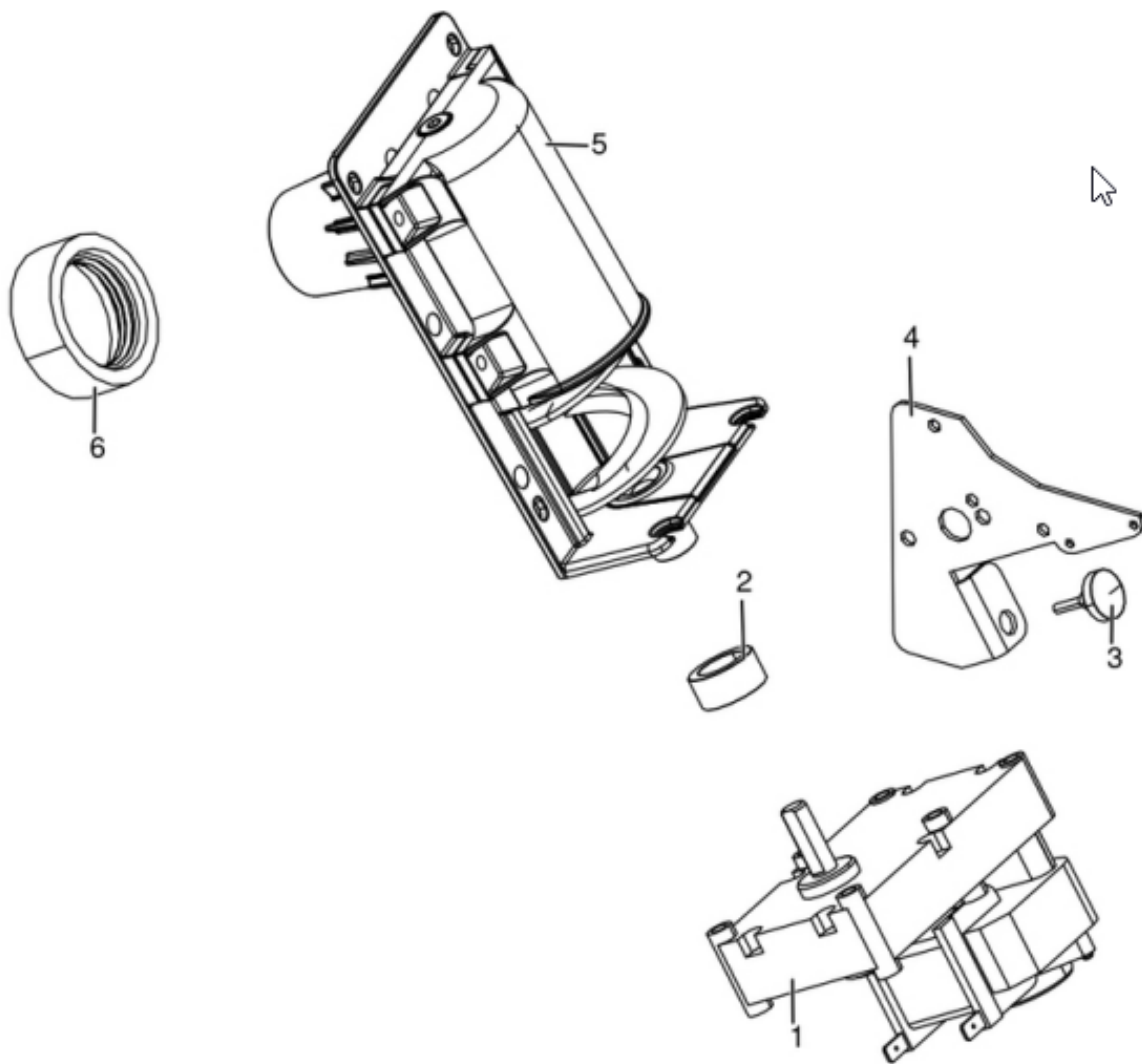

N°	Codice/Code	Descrizioni / Description / Beschreibung / Description / Descripcion
1	4160278	Motoriduttore 1,5 RPM / Reduction motor 1,5 RPM / Getriebemotor 1,5 RPM / Motoréducteur 1,5 TPM / Motorreductor 1,5 RPM
2	4D120183040	Anello Ø 17,2 / Ring Ø 17,2 / Bague Ø 17,2 / Ring Ø 17,2 / Anillo Ø 17,2
3	4D120172010K	Kit 4 paracolpi / Kit 4 Bumpers / Kit 4 Schlagschutzgummi / Kit 4 pièces antichoc / Kit 4 anti-golpes
4	4D241183761	Staffa / Bracket / Bügel / Etrier / Abrazadera
5	4D180177070	Coclea di caricamento pellet / Pellet feed screw / Pelletsförderschnecke / Vis sans fin pour chargement du pellet / Cóclea de carga pellet
6	4D18013003	Guarnizione D.50 mm / Gasket D.50 mm / Dichtung D.50 mm / Joint D.50 mm / Junta D.50 mm

FRAME3 9KW

Gruppo elettrico ed elettronico fino al SN 2007156050001 escluso / Electrical and electronic group up to SN 2007156050001 excluded / Elektrische und elektronische Gruppe bis zur SN 2007156050001 ausgeschlossen / Group électrique et électronique jusqu'au NS 2007156050001 exclue / Grupo eléctrico y electrónico hasta NS 2007156050001 excluido

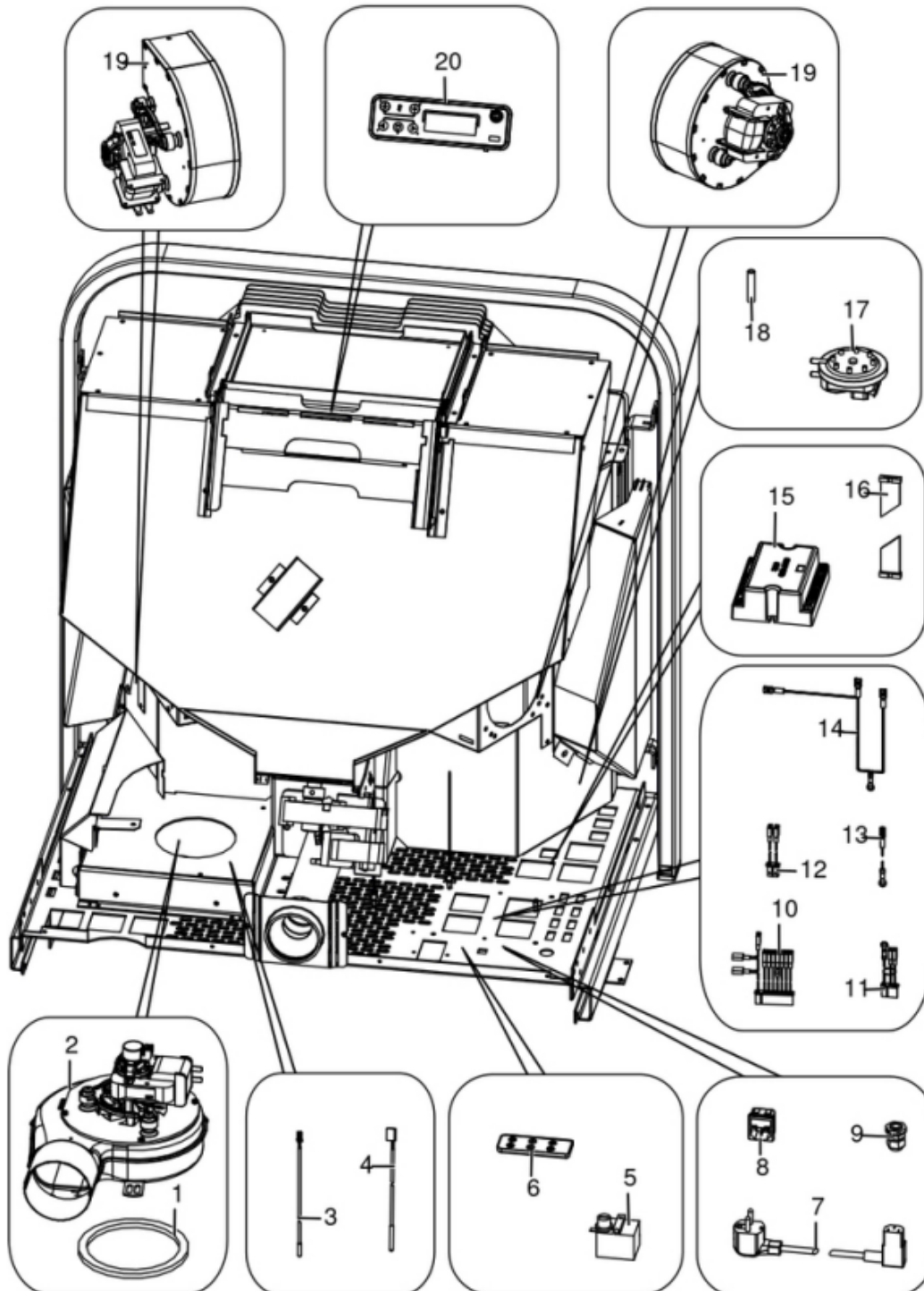

N°	Codice/Code	Descrizioni / Description / Beschreibung / Description / Descripcion
1	4D18013024	Guarnizione / Gasket / Dichtung / Joint / Junta
2	4D145140150	Ventilatore fumi stagno / Air-tight smoke exhausted fan / Luftdichtes Rauchgasgebläse / Ventilateur fumées étanche / Ventilador humos hermético
2	41451209300	Encoder per ventilatore fumi marchi LN2/SIT / Encoder for LN2/SIT smoke fan / Encoder für LN2/SIT Rauchgasgebläse / Encoder pour ventilateur des fumées marques LN2/SIT / Encoder para ventilador humos marcas LN2/SIT
3	4D145150100	Sonda ambiente / Room temperature sensor / Raumtemperaturfühler / Sonde température ambiance / Sonda ambiente
4	4D145150060	Sonda fumi / Smoke sensor / Rauchsonde / Sonde fumées / Sonda humos
5	4D14513051	Termostato / Thermostat / Thermostat / Thermostat / Termostato
6	5019012	Telecomando / Remote control / Fernbedienung / Télécommande / Mando a distancia
7	4D14513041	Cavo alimentazione / Power source cable / Zündungskabel / Câble alimentation / Cable alimentación
8	4D14513084	Cavo con spina Shucko / Cable with Shucko plug / Kabel mit Schucko Steckdose / Cable avec fiche Shucko / Cable con enchufe Schucko
9	4D14513018	Pressacavo + cont. Dado / Cable holder / Kabelklemme / Presse-cable / Presionacable
10	4D145183010	Cablaggio 8 Pin completo / Complete wiring kit 8 Pin / Komplette Verkabelung 8 Pin / Câblage complet 8 Pin / Cableado completo 8 Pin
11	4D145183040	Cablaggio 3 Pin completo / Complete wiring kit 3 Pin / Komplette Verkabelung 3 Pin / Câblage complet 3 Pin / Cableado completo 3 Pin
12	4D145183020	Cablaggio ventilatore 2 Pin / 2 Pin fan cable / 2 Pin Ventilatorverkabelung / Câblage 2 Pin pour ventilateur / Cableado 2 Pin del ventilador
13	4D14513060	Cavo massa 130 mm / Mass cable 130 mm / Masse Kabel 130 mm / Cable masse 130 mm / Cable masa 130 mm
14	4D145183030	Cavo massa 1450 mm / Mass cable 1450 mm / Masse Kabel 1450 mm / Cable masse 1450 mm / Cable masa 1450 mm
15	4D145185010B	Scheda madre / Motherboard / Hauptplatine / Carte mère / Tarjeta madre
16	4D145158020	Cavo flat scheda-pannello / Flat cable motherboard-control panel / Flat Kabel Hauptplatine-Bedienblende / Câble flat carte mère-panneau commande / Cable flat tarjeta madre-panel de mandos
17	4160482	Pressostato 0,4 mbar / Pressure gauge 0,4 mbar / Druckwächter 0,4 mbar / Pressostat 0,4 mbar / Presostato 0,4 mbar
18	4120631A	Tubicino siliconico - 5m / Silicon tube - 5m / Silikonrohr - 5m / Petit tuyau en silicone - 5m / Tubo silicónico - 5m
19	4D145201070	Ventilatore aria / Air fan / Luftgebläse / Ventilateur air / Ventilador aire
20	4D1451303300	Pannello comandi grafico / Graphic control panel / Graphische Bedienblende / Tableau de commande / Panel de mandos gráfico

FRAME3 9KW

Gruppo elettrico ed elettronico dal SN 2007156050001 incluso / Electrical and electronic group from SN 2007156050001 included / Elektrische und elektronische Gruppe ab SN 2007156050001 eingeschlossen / Group électrique et électronique à partir du NS 2007156050001 incluse / Grupo eléctrico y electrónico a partir de NS 2007156050001 incluido

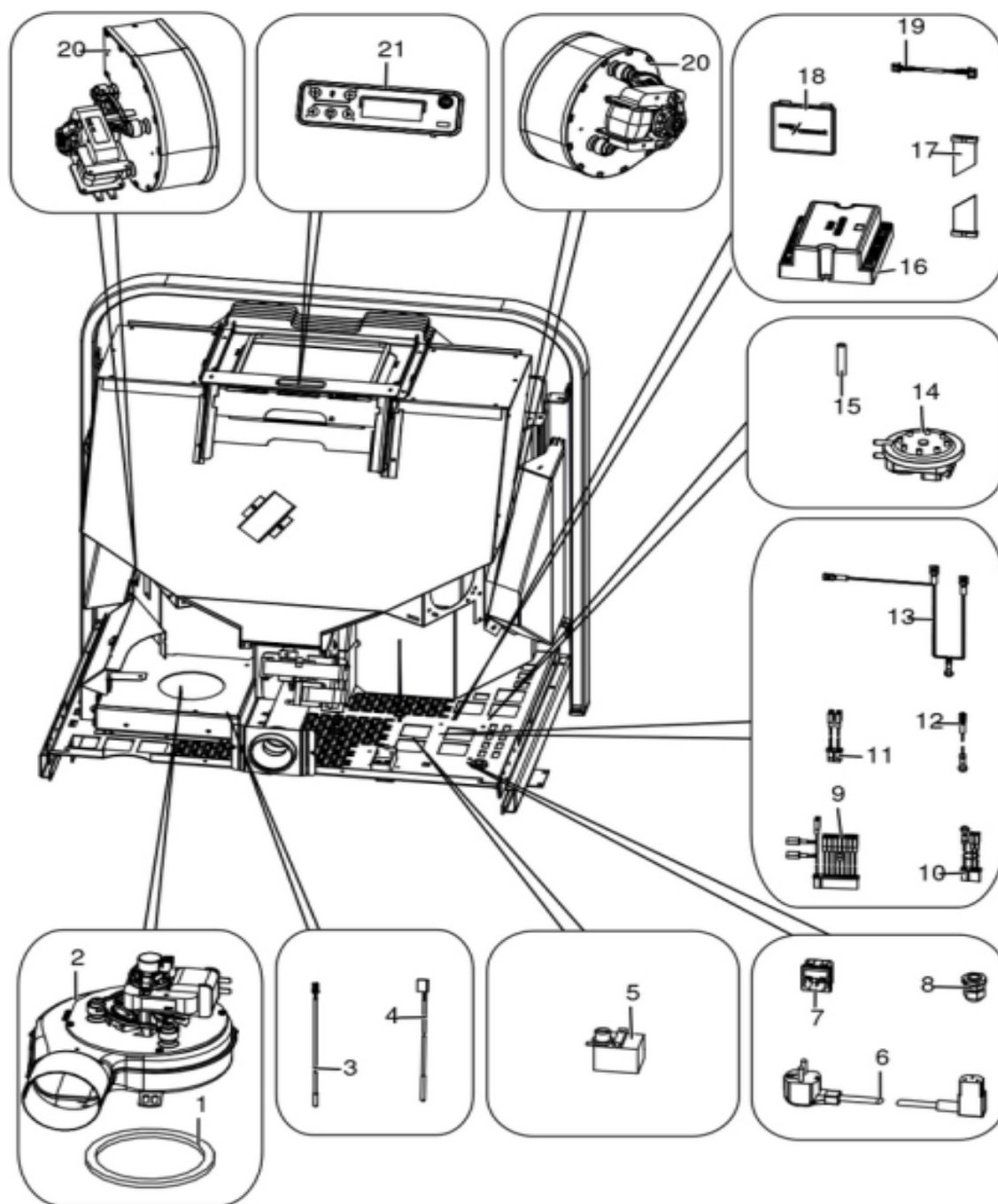

N°	Codice/Code	Descrizioni / Description / Beschreibung / Description / Descripción
1	4D18013024	Guarnizione / Gasket / Dichtung / Joint / Junta
2	4D145140150	Ventilatore fumi stagno / Air-tight smoke exhausted fan / Luftdichtes Rauchgasgebläse / Ventilateur fumées étanche / Ventilador humos hermético
2	41451209300	Encoder per ventilatore fumi marchi LN2/SIT / Encoder for LN2/SIT smoke fan / Encoder für LN2/SIT Rauchgasgebläse / Encoder pour ventilateur des fumées marques LN2/SIT / Encoder para ventilador humos marcas LN2/SIT
3	4D145150100	Sonda ambiente / Room temperature sensor / Raumtemperaturfühler / Sonde température ambiance / Sonda ambiente
4	4D145150060	Sonda fumi / Smoke sensor / Rauchsonde / Sonde fumées / Sonda humos
5	4D14513051	Termostato / Thermostat / Thermostat / Thermostat / Termostato
6	4D14513041	Cavo alimentazione / Power source cable / Zündungskabel / Câble alimentation / Cable alimentación

7	4D14513084	Cavo con spina Shucko / Cable with Shucko plug / Kabel mit Schucko Steckdose / Cable avec fiche Shucko / Cable con enchufe Schucko
8	4D14513018	Pressacavo + cont. Dado / Cable holder / Kabelklemme / Presse-cable / Presionacable
9	4D145183010	Cablaggio 8 Pin completo / Complete wiring kit 8 Pin / Komplette Verkabelung 8 Pin / Câblage complet 8 Pin / Cableado completo 8 Pin
10	4D145183040	Cablaggio 3 Pin completo / Complete wiring kit 3 Pin / Komplette Verkabelung 3 Pin / Câblage complet 3 Pin / Cableado completo 3 Pin
11	4D145183020	Cablaggio ventilatore 2 Pin / 2 Pin fan cable / 2 Pin Ventilator-kabelung / Câblage 2 Pin pour ventilateur / Cableado 2 Pin del ventilador
12	4D14513060	Cavo massa 130 mm / Mass cable 130 mm / Masse Kabel 130 mm / Cable masse 130 mm / Cable masa 130 mm
13	4D145183030	Cavo massa 1450 mm / Mass cable 1450 mm / Masse Kabel 1450 mm / Cable masse 1450 mm / Cable masa 1450 mm
14	4160482	Pressostato 0,4 mbar / Pressure gauge 0,4 mbar / Druckwächter 0,4 mbar / Pressostat 0,4 mbar / Presostato 0,4 mbar
15	4120631A	Tubicino siliconico - 5m / Silicon tube - 5m / Silikonrohr - 5m / Petit tuyau en silicone - 5m / Tubo silicónico - 5m
16	4D1452002400B	Scheda madre / Motherboard / Hauptplatine / Carte mère / Tarjeta madre
17	4D145158020	Cavo flat scheda-pannello / Flat cable motherboard-control panel / Flat Kabel Hauptplatine-Bedienblende / Câble flat carte mère-panneau commande / Cable flat tarjeta madre-panel de mandos
18	4D145201030	Modulo Wi-fi / Wi-fi module / Wi-Fi-Modul / Module Wi-fi / Módulo wifi
19	4D1452002500	Cavo flat 7 vie / Flat cable / Flat-Kabel / Cable flat / Cables flat
20	4D145201070	Ventilatore aria / Air fan / Luftgebläse / Ventilateur air / Ventilador aire
21	4D145201070	Ventilatore aria / Air fan / Luftgebläse / Ventilateur air / Ventilador aire
21	4D1451303300	Pannello comandi grafico / Graphic control panel / Graphische Bedienblende / Tableau de commande / Panel de mandos gráfico

FRAME3 9KW

Componenti canalizzazione aria / Componenti canalizzazione aria / Componenti canalizzazione aria /
Componenti canalizzazione aria / Componenti canalizzazione aria

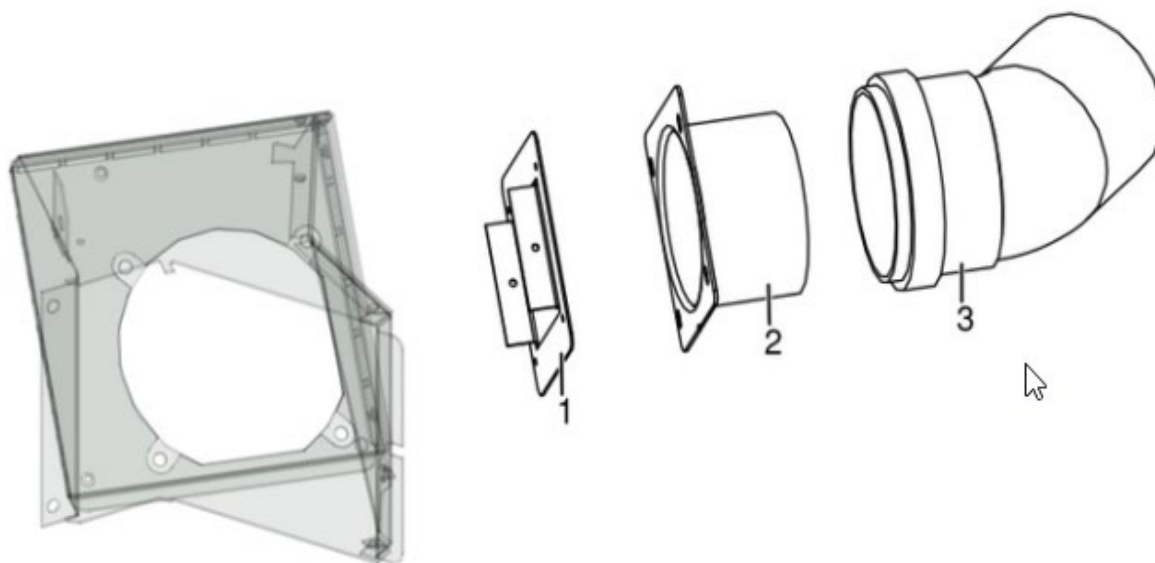

N°	Codice/Code	Descrizioni / Description / Beschreibung / Description / Descripcion
1	4D241140083	Flangia / Flange / Flansche / Bride / Brida
2	4D14513040	Raccordo D.80 mm / Connector D.80 mm / Anschlußrohr D.80 mm / Raccord D.80 mm / Racor D.80 mm
3	40160468	Curva 45° / Curve 45° / Bogen 45° / Courbe 45° / Curva 45°

FRAME3 9KW

5018009 kit canalizzazione / 5018009 kit canalizzazione / 5018009 kit canalizzazione / 5018009 kit canalizzazione / 5018009 kit canalizzazione

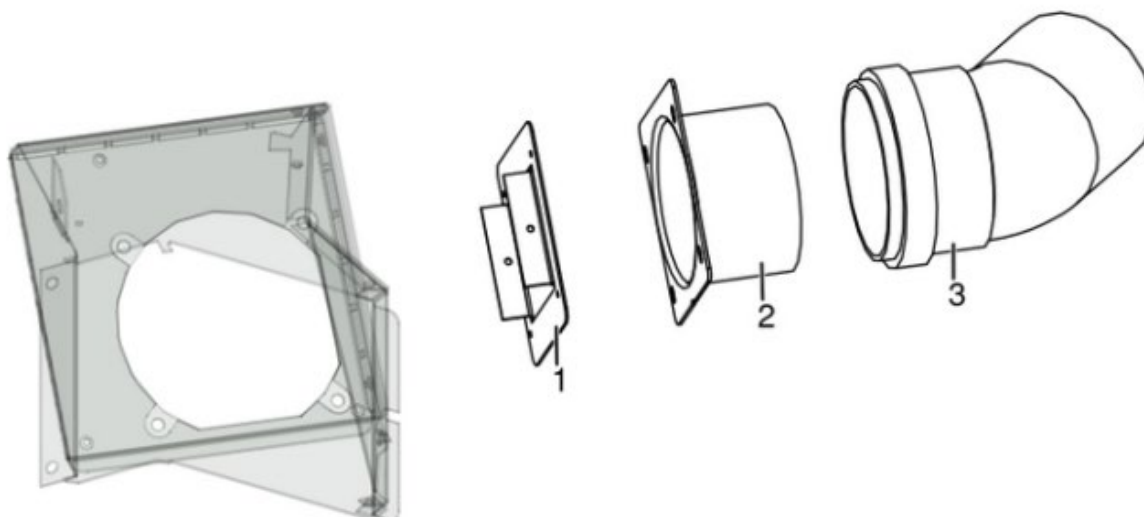

N°	Codice/Code	Descrizioni / Description / Beschreibung / Description / Descripcion
1	4D241140083	Flangia / Flange / Flansche / Bride / Brida
2	4D14513040	Raccordo D.80 mm / Connector D.80 mm / Anschlußrohr D.80 mm / Raccord D.80 mm / Racor D.80 mm
3	40160468	Curva 45° / Curve 45° / Bogen 45° / Courbe 45° / Curva 45°

FRAME3 9KW

5018013 kit scivolo caricamento pellet / 5018013 Pellet feeding sliding kit / 5018013 Kit Rutsche für Pelletversorgung / 5018013 Kit goulotte chargement pellet / 5018013 Kit rampa de carga de pellets

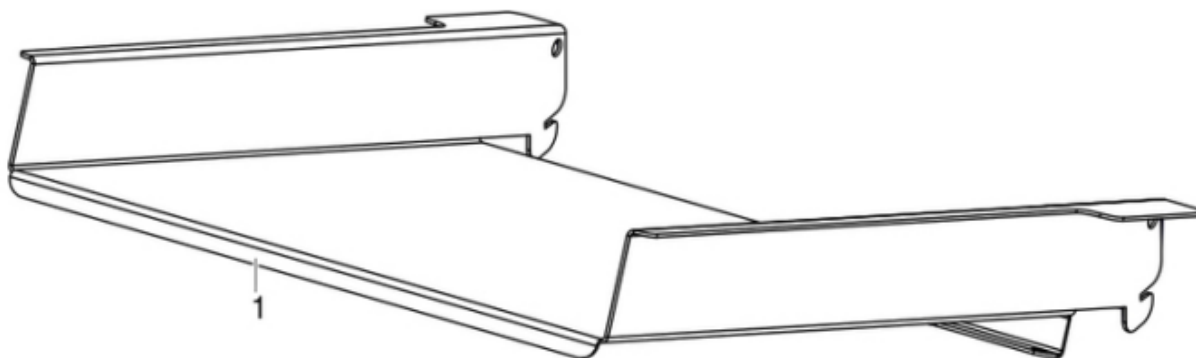

N°	Codice/Code	Descrizioni / Description / Beschreibung / Description / Descripción
1	5018013	kit scivolo caricamento pellet / Pellet loading chute kit / Pellet-Laderutschen-Kit / kit de goulotte de chargement de granulés / kit rampa de carga de pellets

FRAME3 9KW

5018010 kit scarico fumi superiore / 5018010 Smoke outlet up kit / 5018010 Kit Rauchabzug oben / 5018010 Kit sortie fumées supérieure / 5018010 Kit salida de humo superior

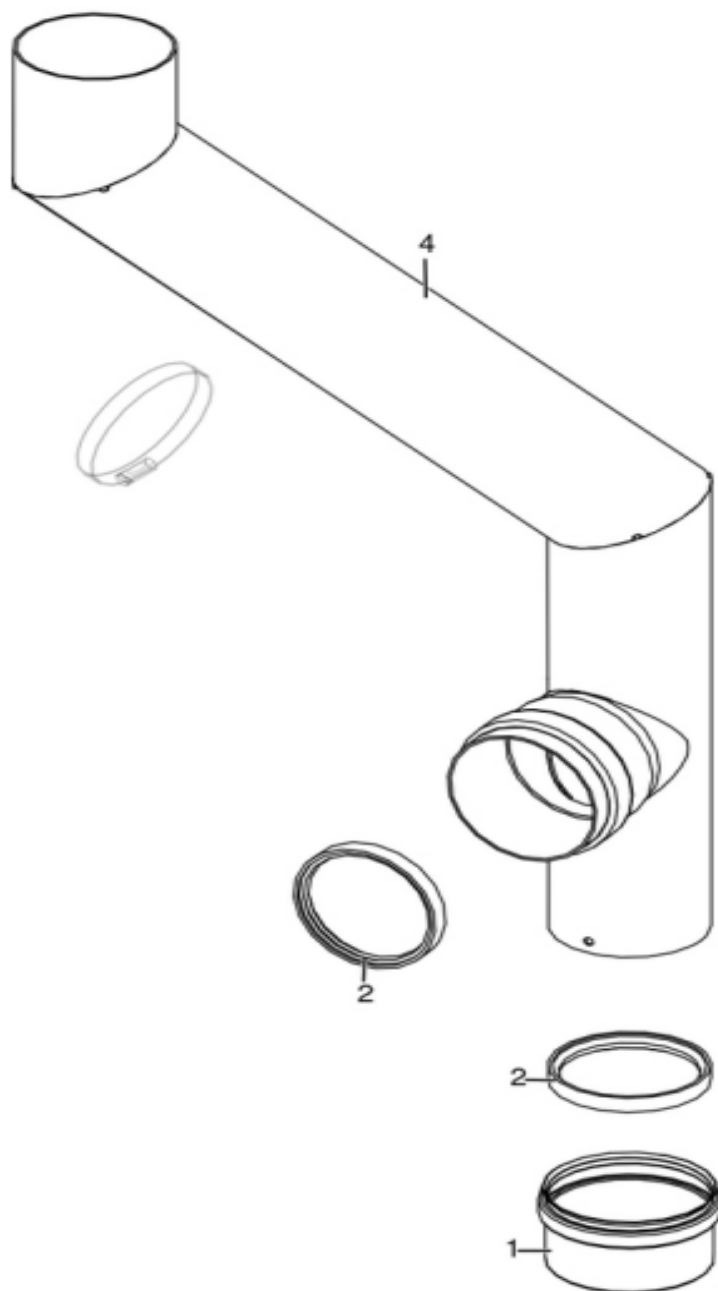

N°	Codice/Code	Descrizioni / Description / Beschreibung / Description / Descripcion
1	4D14013065	Tappo raccordo D. 80 / Junction plug D.80 / Anschlussdeckel D.80 / Bouchon de raccordement D.80 / Tapón raccor D.80
2	4D180157020	Guarnizione siliconica rossa / Red silicon gasket / Rote Silikonsichtung / Join en silicon rouge / Junta de silicona roja
3	4D16018315061	Tubo scarico fumi / Smoke outlet pipe / Rauchabzugrohr / Conduit d'evaquation des fumées / Tubo evacuación de humo