

**FENICE 11 PLUS**

Gruppo estetico / Aesthetic group / Ästhetische Gruppe / Groupe esthétique / Grupo estético

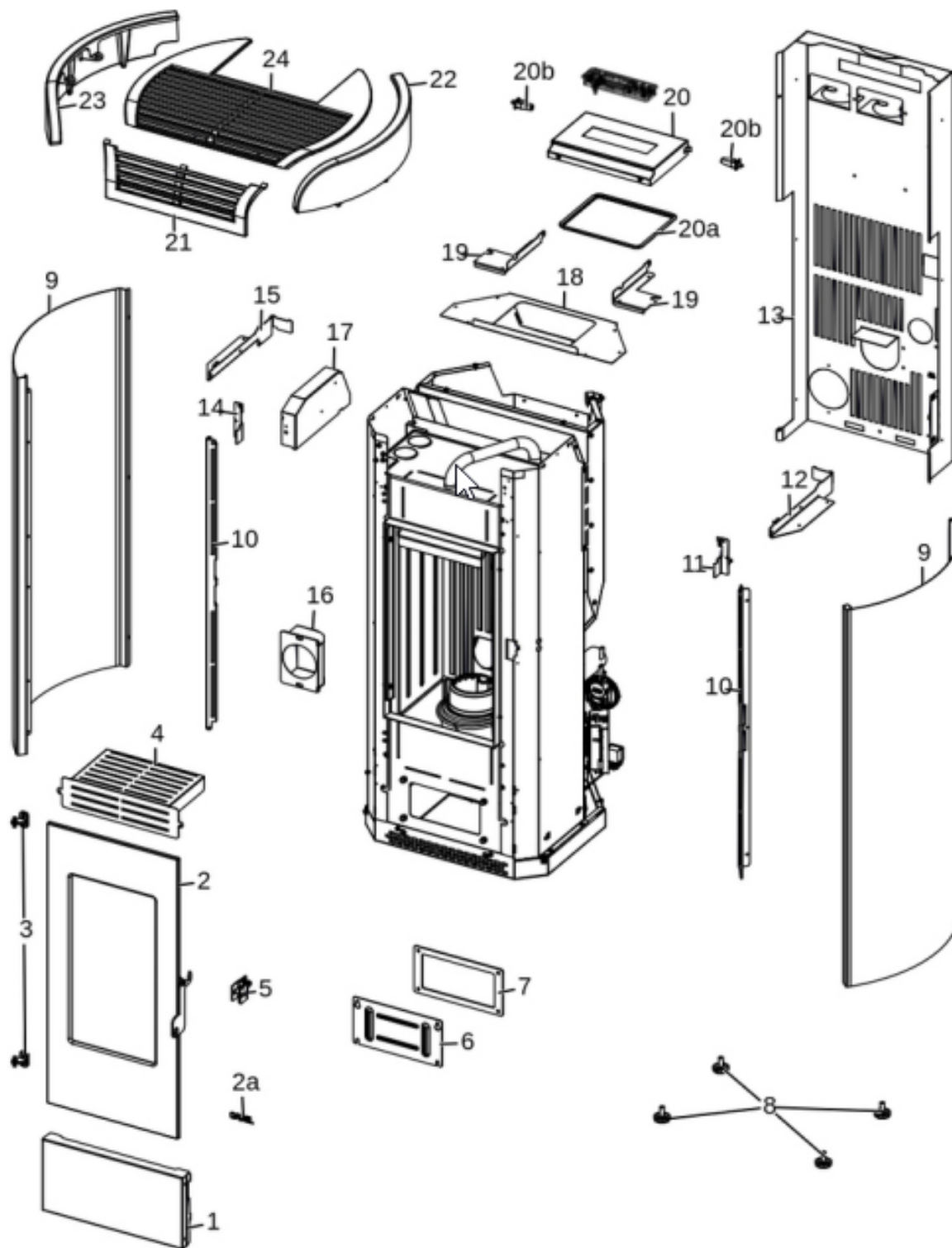

N°	Codice/Code	Descrizioni / Description / Beschreibung / Description / Descripción
1	4D24021033363	* / * / * / * / *
2	4D245GP22002	* / * / * / * / *
2a	4D12013039	Logo Cadel / Cadel logo / Cadel Logo / Cadel logo / Cadel logo
3	41201504460	Cerniera porta (2 pz.) / Door hinge (2 pc.) / Tür Scharnier (2 Stk.) / Charnière porte (2 pc.) / Bisagra puerta (2)
4	4D24021080361	* / * / * / * / *
5	4D24015841361	Kit decompressione camera di combustione / Pressure relief kit / Bausatz Überdruckablauf Brennkammer / Kit decompression chambre de combustion / Kit decompression cámara de combustión
6	41401339610	Tappo ispezione vano fumi / Smoke compartment inspection plug / Inspektionsdeckel Rauchabzug / Clapet inspection compartiment fumées / Tapón inspección compartimento humos
7	41800900600	Guarnizione / Gasket / Dichtung / Joint / Junta
8	4D120201020	Piedino (4 pz) / Feet (4 Pcs) / Füße (4 Stck) / Vérins (4 Pcs) / Pies (4 pz)
9	4D24021075340	Fianco dx-sx antracite / Anthracite RH-LH side / Rechtes/linkes Seitenteil Anthrazit / Panneau droite et gauche anthracite / Flanco derecho y izquierdo antracita
9	4D24021075396	* / * / * / * / *
9	4D24021075398	* / * / * / * / *
10	4D24021073361	* / * / * / * / *
11	4D24021076361	* / * / * / * / *
12	4D24021082361	* / * / * / * / *
13	4D240210773	* / * / * / * / *
14	4D24021074361	* / * / * / * / *
15	4D24021072361	* / * / * / * / *
16	4D24014023363	Diffusore aria calda / Hot air diffuser / Warmluftdiffusor / Diffuseur air chaude / Difusor aire caliente
17	4D24021043361	* / * / * / * / *
18	4D241210253	* / * / * / * / *
19	4D24021022363	* / * / * / * / *
20	4D245GD22001	Coperchio pellet / Pellet hopper cover / Deckel Pelletbehälter / Couvercle réservoir pellet / Tapadera depósito pellet
20a	4D18013016	Guarnizione 155X190 mm / Gasket 155X190 mm / Dichtung 155x190 mm / Joint 155X190 mm / Junta 155X190 mm
20b	4D14013054C	Cerniera a innesto (2 pz) / Hinge (2 pc) / Scharnier (2 Stck) / Charnière (2 pcs) / Bisagra (2 pzs)
21	4D13021005061	* / * / * / * / *
22	4D13021007020	* / * / * / * / *
22	4D13021007040	* / * / * / * / *
22	4D13021007098	* / * / * / * / *
23	4D13021006020	* / * / * / * / *
23	4D13021006040	* / * / * / * / *
23	4D13021006098	* / * / * / * / *
24	4D13021004061	* / * / * / * / *

## FENICE 11 PLUS

Porta fuoco / Fire door / Feuertür / Porte foyer / Puerta hogar

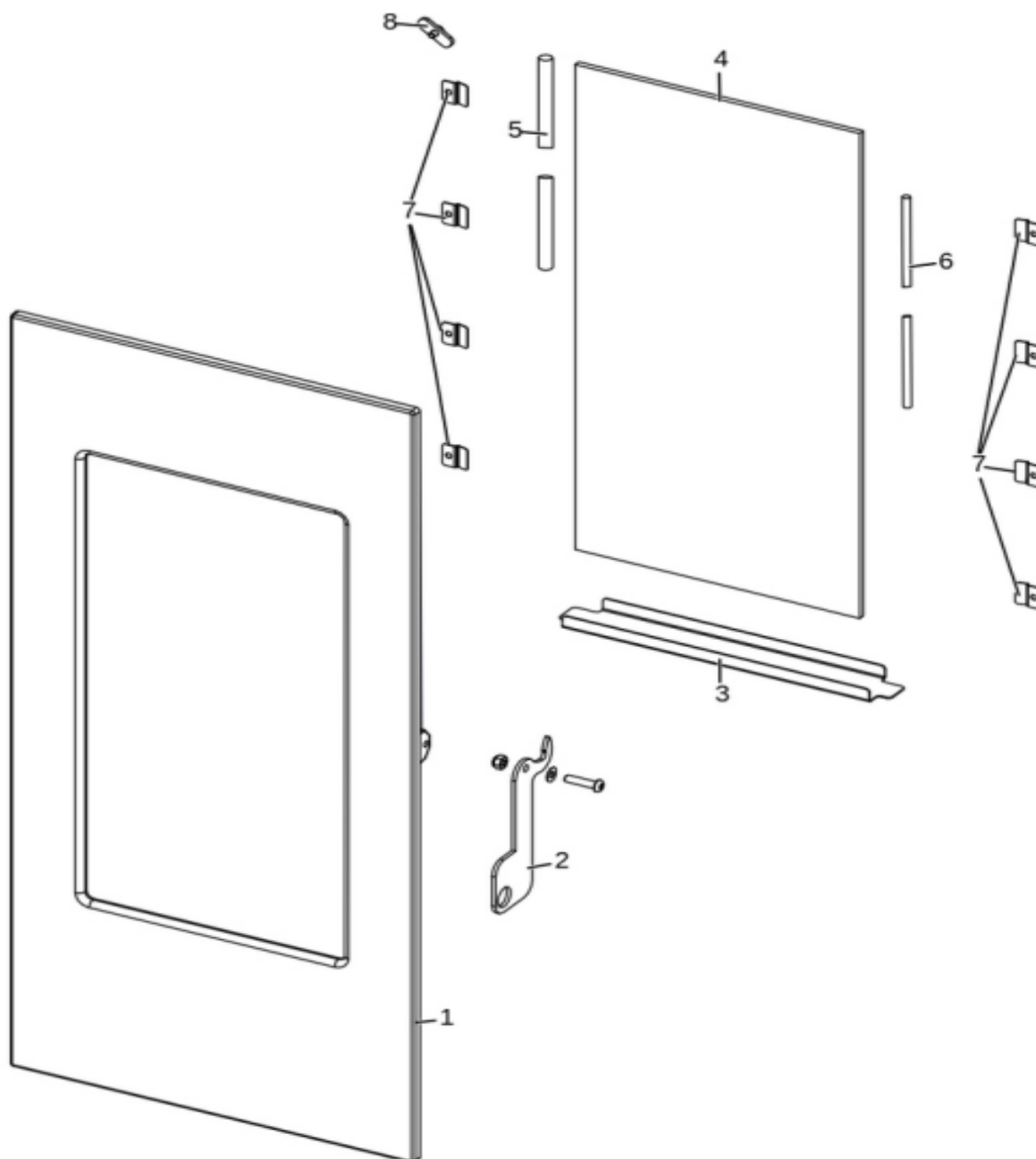

N°	Codice/Code	Descrizioni / Description / Beschreibung / Description / Descripcion
1	4D13021009061	* / * / * / * / *
2	4D24016014161	Maniglia / Handle / Griff / Poignée / Tirador
3	4D241210273	* / * / * / * / *
4	4D170210020	* / * / * / * / *
5	4D18013021A	Guarnizione treccia nera D.10 - 5 M / Black twist gasket D.10 - 5 M / Dichtung D.10 - 5 M / Joint tresse noire D.10 - 5 M / Junta D.10 - 5 M
5	4D18013021B	Guarnizione treccia nera D.10 - 50 M / Black twist gasket D.10 - 50 M / Dichtung D.10 - 50 M / Joint tresse noire D.10 - 50 M / Junta D.10 - 50 M
6	4D18013034A	Guarnizione Tricotex D.6mm (5m) / Gasket Tricotex D.6mm (5m) / Dichtung Tricotex D.6mm (5m) / Joint Tricotex D.6mm (5m) / Junta Tricotex D.6mm (5m)
6	4D18013034B	Guarnizione Tricotex D.6mm (50m) / Gasket Tricotex D.6mm (50m) / Dichtung Tricotex D.6mm (50m) / Joint Tricotex D.6mm (50m) / Junta Tricotex D.6mm (50m)
7	4D2401317703	Fermavetro (pz.2) / Glass fastening brackets (pcs.2) / Haltebügel für Scheibenbefestigung (stk.2) / Etrier de fixation de la vitre (pcs.2) / Retenedor del cristal (pz.2)
8	4D240157991	Asola porta / Door lock hole / Schleife für Türblockierung / Boucle de porte / Ojal de la puerta

## FENICE 11 PLUS

Gruppo camera di combustione / Combustion chamber group / Verbrennungskammer Gruppe / Group de chambre de combustion / Grupo cámara de combustión

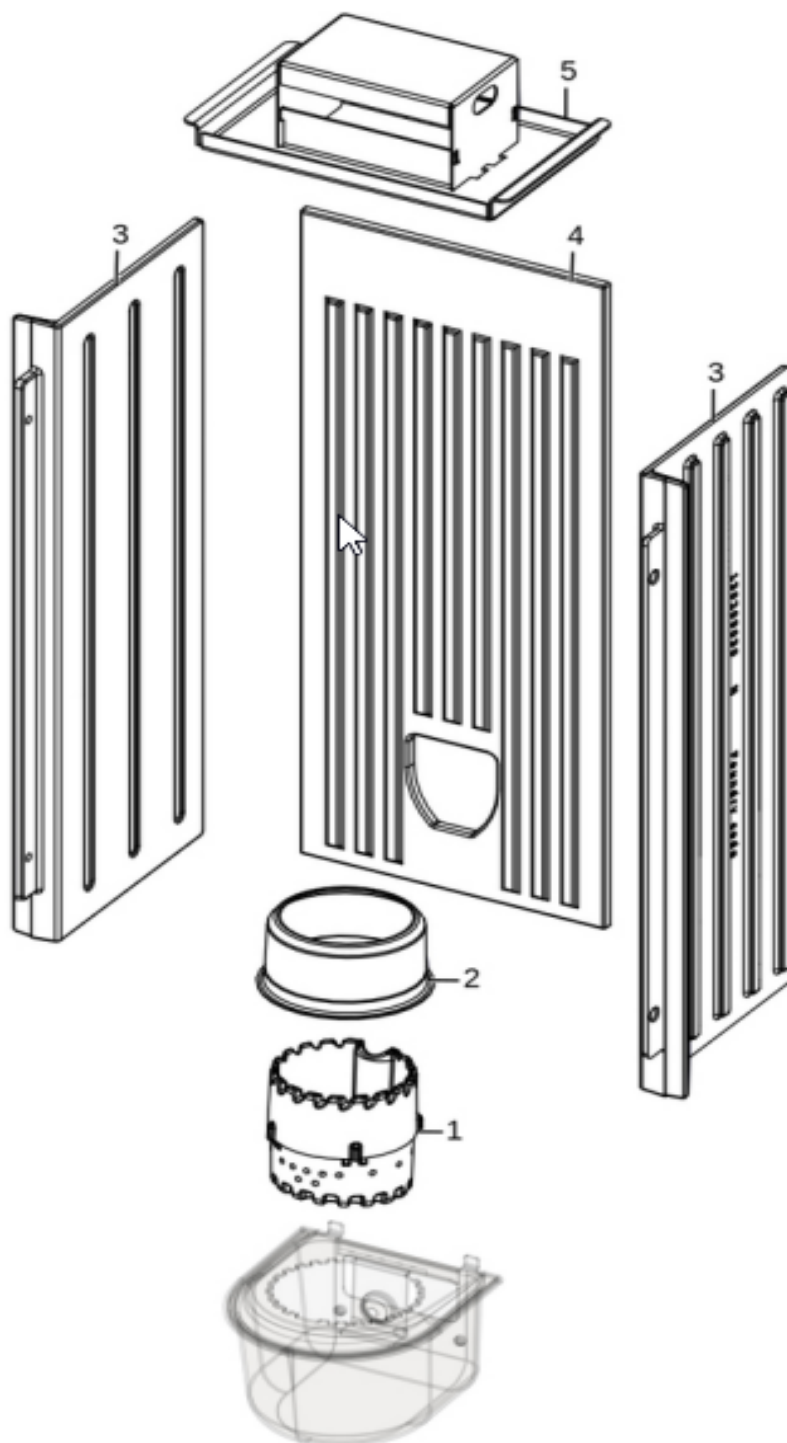

N°	Codice/Code	Descrizioni / Description / Beschreibung / Description / Descripción
1	4D13021003061	* / * / * / * / *
2	4D140210020	* / * / * / * / *
3	4D13020903061	Tavella in ghisa / Cast iron panel / Gusseisenpaneel / Panneau en fonte / Mesa de hierro fundido
4	4D13021008062	* / * / * / * / *
5	4D242210033	* / * / * / * / *

## FENICE 11 PLUS

Gruppo caricamento pellet / Pellet feed group / Pellet Fördergruppe / Groupe chargement du pellet / Grupo de carga pellet

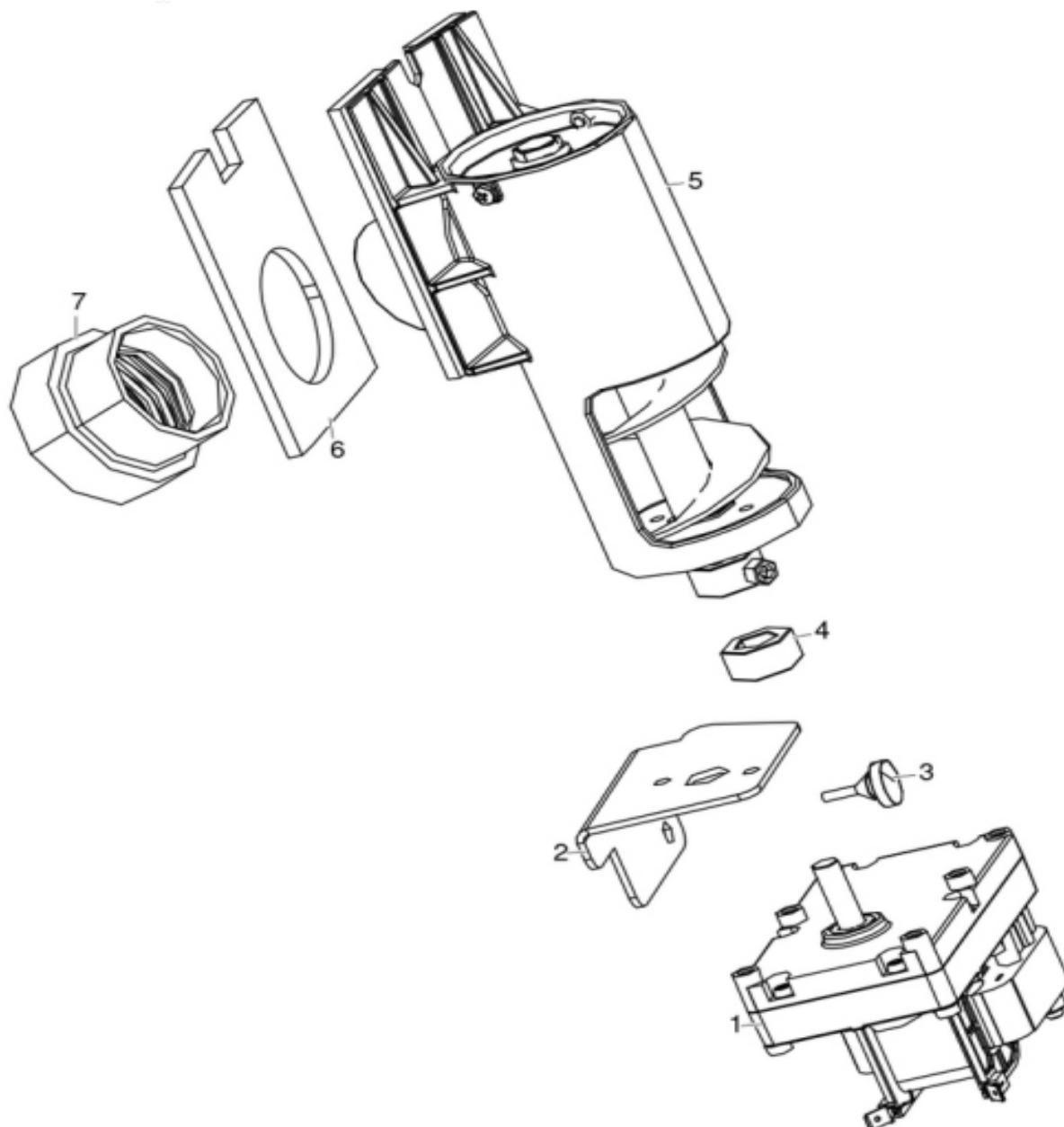

N°	Codice/Code	Descrizioni / Description / Beschreibung / Description / Descripción
1	4D145181020	Motoriduttore 2 rpm / Reduction motor 2 rpm / Getriebemotor 2 rpm / Motoréducteur 2 rpm / Motorreductor 2 rpm
2	4D240209133	Staffa motoriduttore / Gearmotor bracket / Getriebemotor Halterung / Support de motoréducteur / Soporte motorreductor
3	4D120172010K	Kit 4 paracolpi / Kit 4 Bumpers / Kit 4 Schlagschutzgummi / Kit 4 pièces antichoc / Kit 4 anti-golpes
4	4120398	Connettore motoriduttore-coclea / Reduction motor-feed screw connector / Verbindung Getriebemotor-Schnecke / Connecteur motoréducteur-vis sans fin / Conector motorreductor-cóclea
5	4D140209050	Coclea con albero / Feed screw with shaft / Förderschnecke mit Welle / Vis d'alimentation avec arbre / Sinfín con eje
6	41802000300	Guarnizione con ceramica gruppo alimentazione / Gasket with ceramic - power supply group / Dichtung mit Keramik - Stromversorgungsgruppe / Joint avec céramique - groupe d'alimentation / Junta con cerámica - grupo de alimentación
7	41801702600	Disaccoppiatore coclea / Feed screw gasket / Dichtung Pelletrutsche / Joint vis sans fin / Desacoplador cóclea

## FENICE 11 PLUS

Gruppo accensione e aria comburente / Ignition and combustion air group / Entzündungs- und Verbrennungsluftgruppe / Groupe allumage et aire comburente / Grupo encendido y aire de combustion

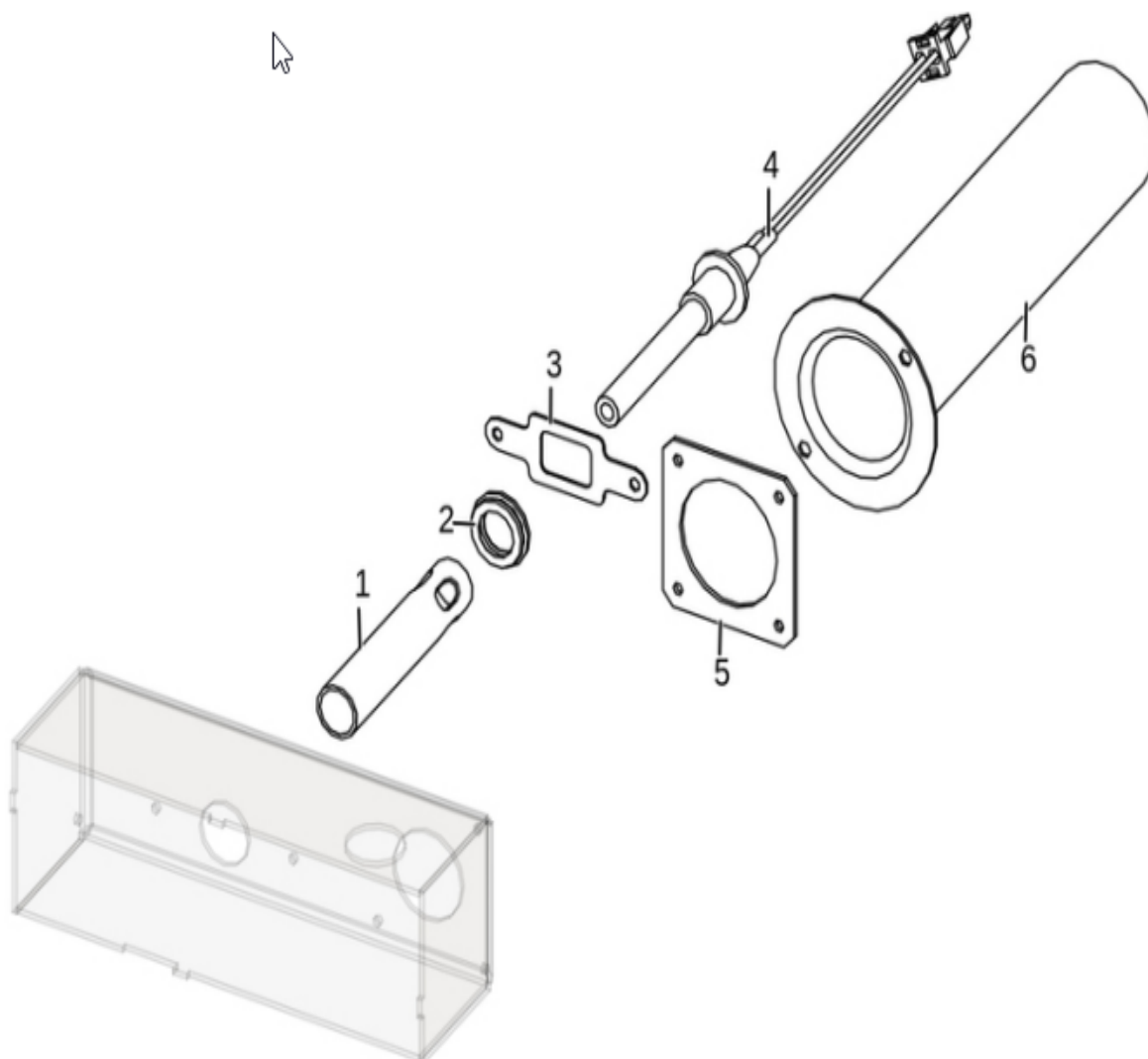

N°	Codice/Code	Descrizioni / Description / Beschreibung / Description / Descripcion
1	4D160210110	* / * / * / * / *
2	4D180201030	Guarnizione tubo candeledda Ø28 / Ø28 sparkplug tube gasket / Ø28 Glühkerzen Rohrdichtung / Joint de tube de bougie de préchauffage Ø28 / Junta tubo bujía incandescente Ø28
3	4D241210161	* / * / * / * / *
4	41452009900	CANDELETTA 300 WATT / SPARKPLUG 300 WATT / ZÜNDKERZE 300 WATT / BOUGIE 300 WATT / BUJÍA 300 WATT
5	41801200300	Guarnizione collettore aria / Air manifold gasket / Luftkollektor Dichtung / Joint collecteur air / Burllete del colector aire
6	4D160210100	* / * / * / * / *



## FENICE 11 PLUS

Gruppo elettrico ed elettronico / Electrical and electronic group / Elektrische und elektronische Gruppe /  
Groupe électrique et électronique / Grupo eléctrico y electrónico

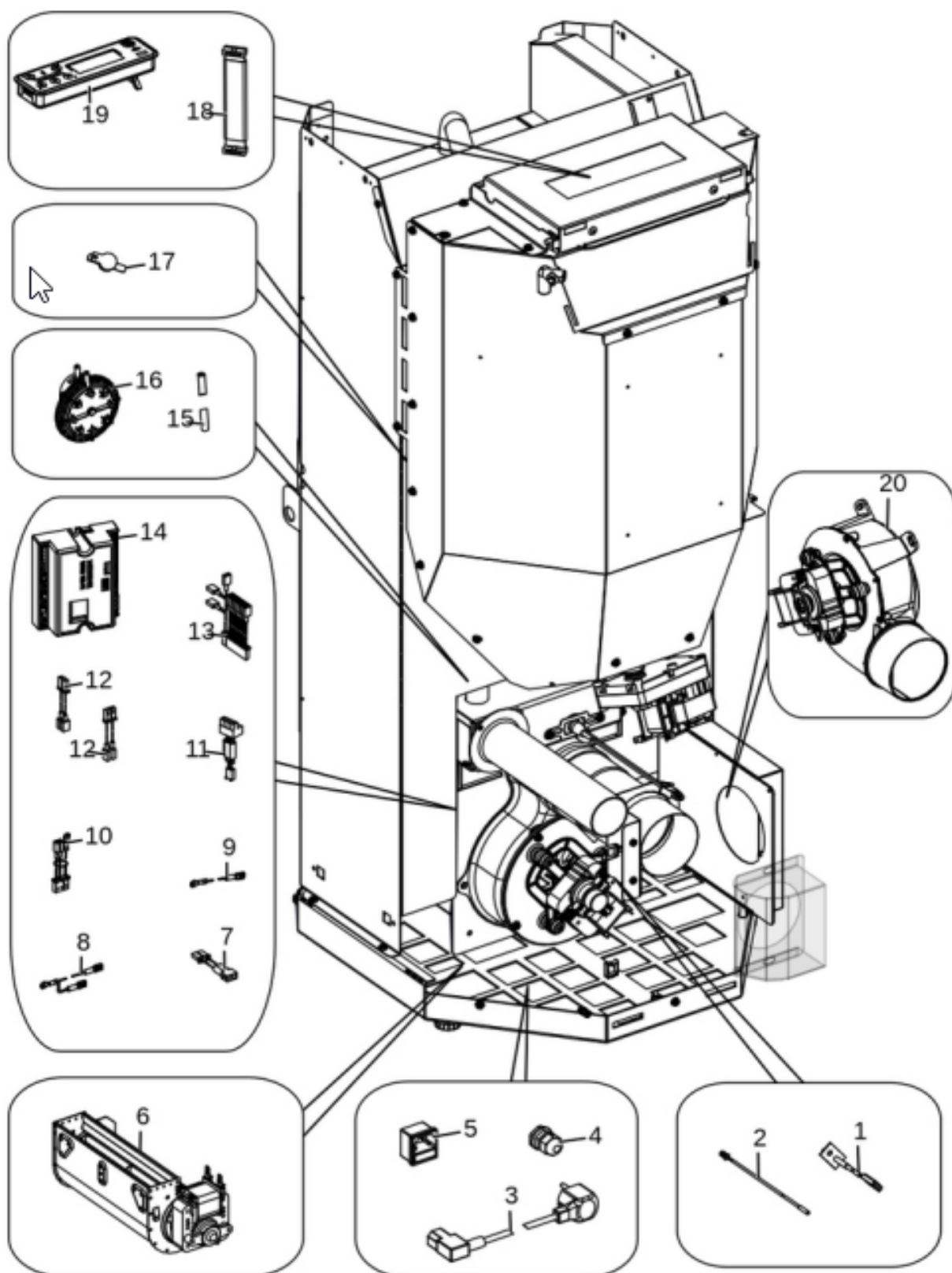

N°	Codice/Code	Descrizioni / Description / Beschreibung / Description / Descripción
1	4D145194010	Sonda fumi / Smoke sensor / Rauchgasfühler / Sonde fumées / Sonda humos
2	4D145150100	Sonda ambiente / Room temperature sensor / Raumtemperaturfühler / Sonde température ambiance / Sonda ambiente
3	4D14513041	Cavo alimentazione / Power source cable / Zündungskabel / Câble alimentation / Cable alimentación
4	4D14513018	Pressacavo + cont. Dado / Cable holder / Kabelklemme / Presse-cable / Presionacable
5	4D14513084	Cavo con spina Shucko / Cable with Shucko plug / Kabel mit Schucko Steckdose / Cable avec fiche Shucko / Cable con enchufe Schucko
6	4D145210150	Ventilatore dx / Right fan / Ventilator rechts / Ventilateur droit / Ventilador derecho
7	4D145210090	* / * / * / * / *
8	4D145201040	Cavo massa / Grounding wiring / Erdungskabel / Câbla mise à terre / Cableado a tierra
9	4D145140110	Cavo massa 280 mm / Mass cable 280 mm / Masse Kabel 280 mm / Cable masse 280 mm / Cable masa 280 mm
10	4D14513045	Cablaggio 3 Pin completo / Complete wiring kit 3 Pin / Komplette Verkabelung 3 Pin / Câblage complet 3 Pin / Cableado completo 3 Pin
11	4D145209120	Cavo encoder / Encoder cable / Encoder Kabel / Câble encoder / Cable encoder
12	4D145183020	Cablaggio ventilatore 2 Pin / 2 Pin fan cable / 2 Pin Ventilatorverkabelung / Câblage 2 Pin pour ventilateur / Cableado 2 Pin del ventilador
13	4D145210080	* / * / * / * / *
14	4D1452002401	* / * / * / * / *
15	4120631A	Tubicino siliconico - 5m / Silicon tube - 5m / Silikonrohr - 5m / Petit tuyau en silicone - 5m / Tubo silicónico - 5m
16	4D145181110	Pressostato / Pressure switch / Druckwächter / Pressostat / Presostato
17	4D14513006	Termostato 60°C / Thermostat 60°C / Thermostat 60°C / Thermostat 60°C / Termostato 60°C
18	4D14513031	Cavo flat scheda-pannello / Flat cable motherboard-control panel / Flat Kabel Hauptplatine-Bedienblende / Câble flat carte mère-panneau commande / Cable flat tarjeta madre-panel de mandos
19	4D145221020	Display con WIFI integrato / Display with integrated WIFI / Display mit integriertem WIFI / Panneau de commande avec WIFI intégré / Display con WIFI integrado
20	4D145209150	Ventilatore / Fan / Lüfter / Ventilateur / Ventilador



## FENICE 11 PLUS

Gruppo fumi / Smoke group / Rauchgruppe / Groupe fumées / Grupo de humos

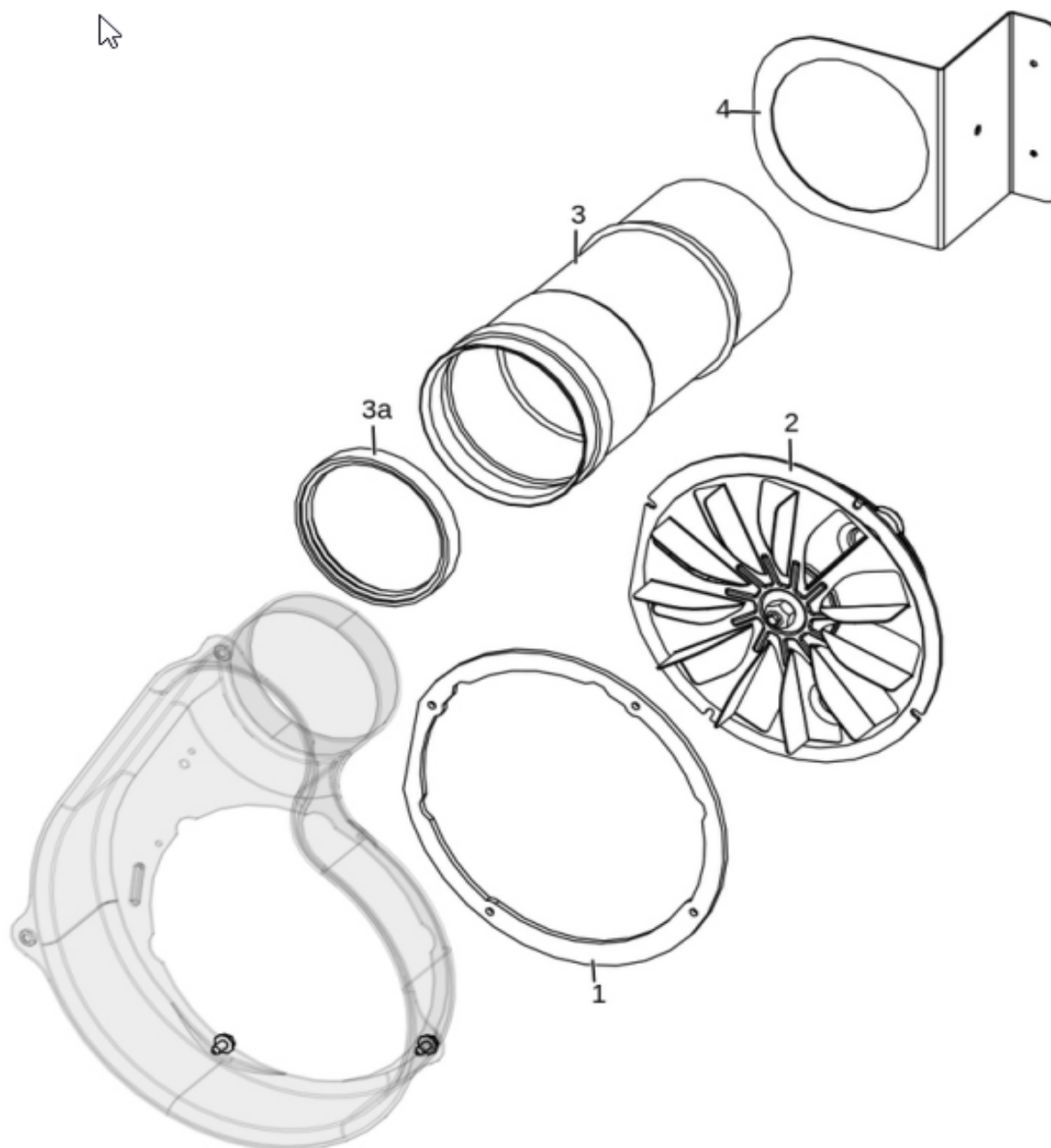

N°	Codice/Code	Descrizioni / Description / Beschreibung / Description / Descripcion
1	4D180209010	Guarnizione / Gasket / Dichtung / Joint / Junta
2	4D145209020	Ventilatore fumi / Smoke exhaust fan / Rauchgasgebläse / Ventilateur aspiration fumées / Ventilador humos
3	4D16013022	Tubo D.80X192 mm / Pipe D.80X192 mm / Rohr D.80X192 mm / Tuyau D.80X192 mm / Tubo D.80X192 mm
3a	4D180157020	Guarnizione siliconica rossa / Red silicon gasket / Rote Silikonsichtung / Join en silicon rouge / Junta de silicona roja
4	4D241209143	Supporto tubo scarico fumi / Smoke exhaust pipe support / Abgasrohr Auslasshalterung / Support de sortie de conduit de fumée / Soporte para tubo de escape de humos